

BRÜCKENKRAN

GANTRY CRANE
GRUE DE PONT
BRUGKRAAN



Art. Nr. 120163

D

Vor Beginn des Bastelns sollten Sie sich mit den Spritzlingen und der Anleitung vertraut machen. Sollte es einmal vorkommen, dass ein Teil im Bausatz fehlt, kreuzen Sie bitte das fehlende Teil in der Anleitung an und schicken Sie diese bitte an Fa. Gebr. FALLER GmbH, Abt. Kundendienst, kundendienst@faller.de, Kreuzstraße 9, 78148 Gütenbach. Sie erhalten dann umgehend Ersatz. In diesem Bausatz sind einige Kunststoffteile übrig.

GB

Before beginning with the assembly please familiarize yourself with the parts and read the instructions carefully. In case of missing parts please indicate these on the instructions leaflet with a circle and return the leaflet to Gebr. FALLER GmbH, kundendienst@faller.de, Kreuzstraße 9, D-78148 Gütenbach, Germany. You will receive the replacement by return. Some of the parts in this box are not needed to construct the model.

F

Avant de commencer le montage de votre maquette bien lire la notice et repérer les grappes. Si une pièce manque dans une boîte, cochez la pièce correspondante sur la notice et renvoyez-la-nous à Gebr. FALLER GmbH, kundendienst@faller.de, Kreuzstraße 9, D-78148 Gütenbach (R.F.A.). Nous vous ferons parvenir la pièce par retour. Dans cette boîte se trouvent quelques pièces qui ne seront pas utilisées pour le montage.

NL

Vóór het bouwen zou men de gietstukken en de handleiding moeten bestuderen. Indien onverhoopt een onderdeel aan het bouwpakket ontbreekt, gelieve men het ontbrekende deel in de handleiding aan te kruisen en deze te zenden aan Gebr. FALLER GmbH, kundendienst@faller.de, Kreuzstraße 9, D-78148 Gütenbach. U ontvangt dan omgaand en gratis het ontbrekende onderdeel. Van dit bouwpakket worden enkele kunststof delen niet gebruikt.

Für den Zusammenbau des Modells empfehlen wir folgende FALLER-Artikel (sind nicht im Bausatz enthalten):
For the assembly of the kit we recommend following FALLER products (not included in the kit):
Pour l'assemblage du modèle, nous vous recommandons les articles FALLER suivants (non inclus dans le kit):
Om dit model te bouwen adviseren wij de volgende FALLER producten (maken geen deel uit van deze bouwset):



Art. Nr. 170492
FALLER-EXPERT

Flüssigkleber in Plastikflasche mit Spezialkanüle für feinste Klebstoffdosierung.

Liquid cement in plastic bottle with canule for very fine dosage.

Colle liquide en bouteille plastique avec bec verseur pour un dosage précis.

Vloeibare lijm in plastic-flescon met doseerbuisje om nauwkeurig te lijmen.



Art. Nr. 170688
SPEZIAL-SEITENSCHNEIDER

zum gratfreien Abtrennen von feinsten Spritzteilen.
Nur für Polystyrol geeignet.

Special side cutter for cutting off ultra-fine moulded parts without burrs.
Only suitable for polystyrene.

Pince coupante spéciale pour couper sans bavure les pièces miniatures moulées par injection. Convient uniquement au polystyrène.

Speciale zijkniptang voor het braamloos afknippen van de fijnste gietstukdelen. Alleen geschikt voor polystyrol.

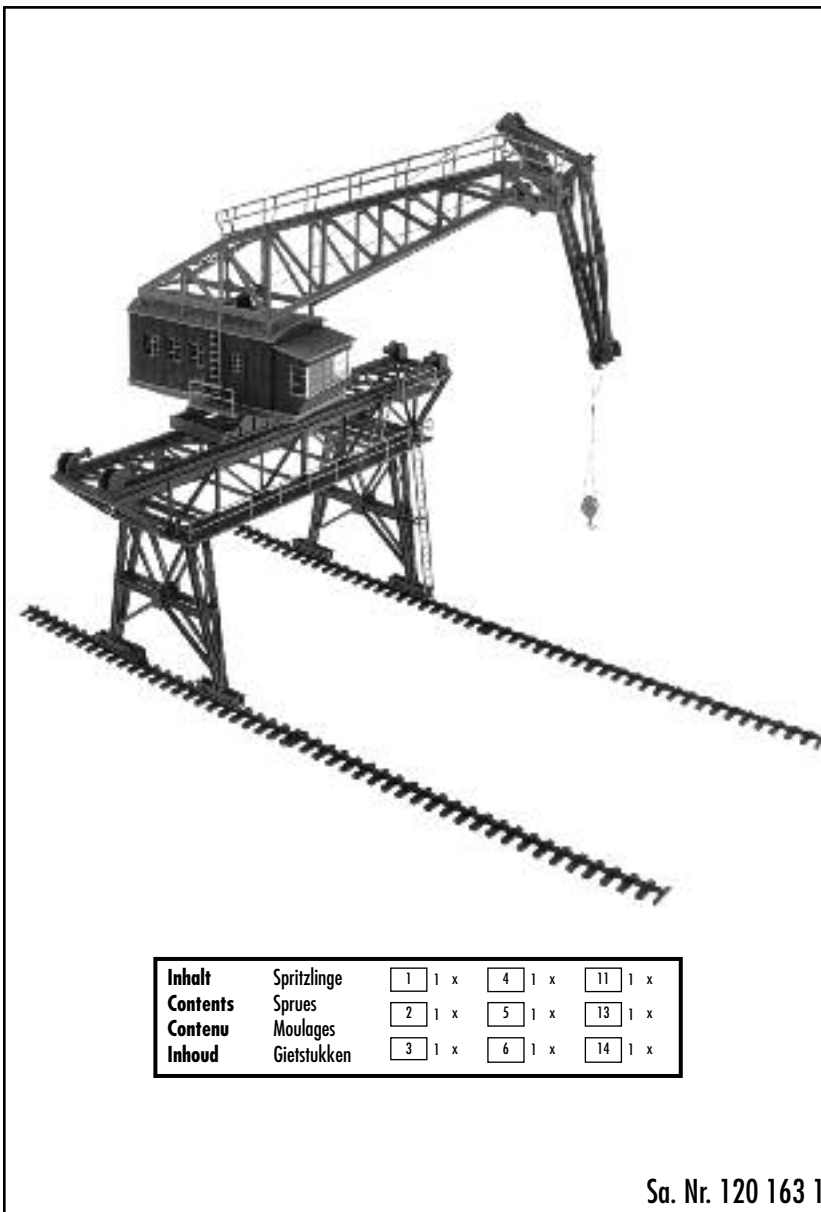

Inhalt	Spritzlinge	1	1 x	4	1 x	11	1 x
Contents	Sprues	2	1 x	5	1 x	13	1 x
Contenu	Moulages	3	1 x	6	1 x	14	1 x
Inhoud	Gietstukken						

Sa. Nr. 120 163 1

Vor Beginn des Bastelns sollten Sie sich mit den Variationsmöglichkeiten des Modells vertraut machen (siehe Seite 9).

Before starting the assembly you should familiarize yourself with the variations of the kit(see page 9).

Avant de commencer l'assemblage, il faut vous familiariser avec les configurations proposées (on pp. 9).

Voor dat u begint met het bouwen adviseren wij u de variatiemogelijkheden van dit bouwmodel te bestuderen (blz. 9).

Variante I



Variante II



Variante III



Variante IV



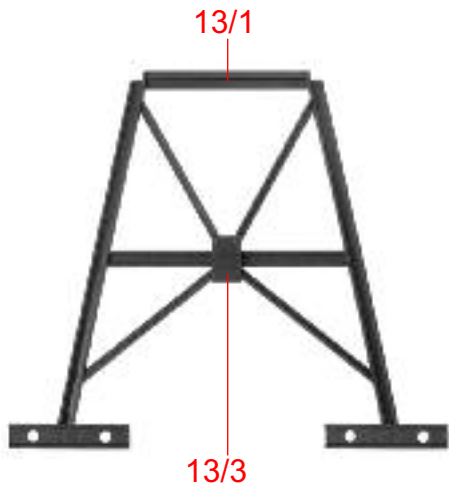

A 4 x



C

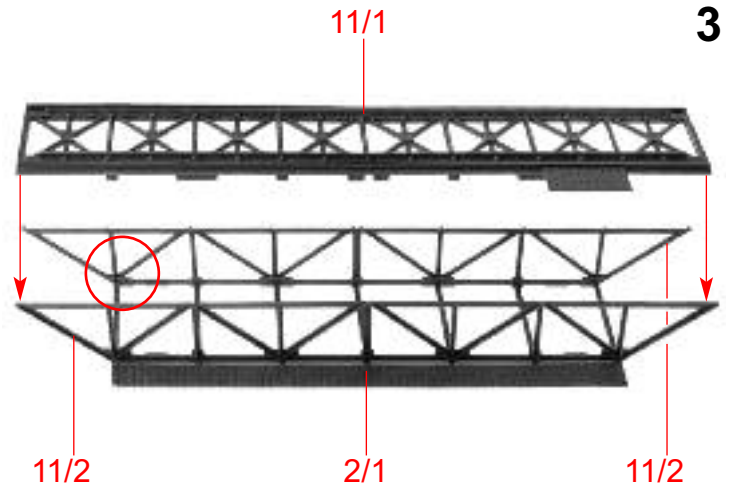

3

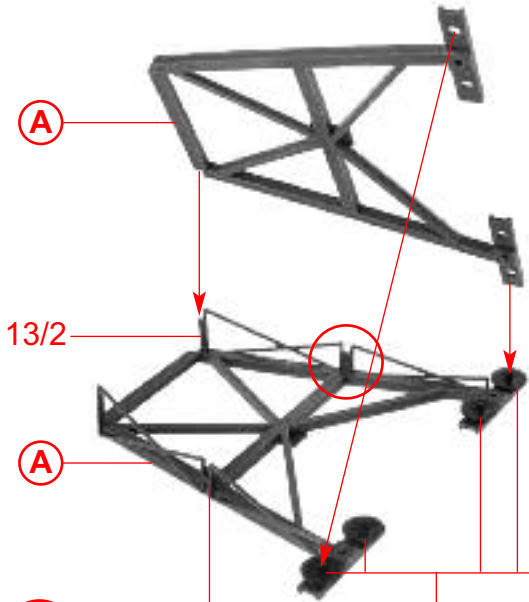

13/2

A

B 2 x 13/2

14/15

nicht kleben
do not glue
ne pas coller
niet lijmen

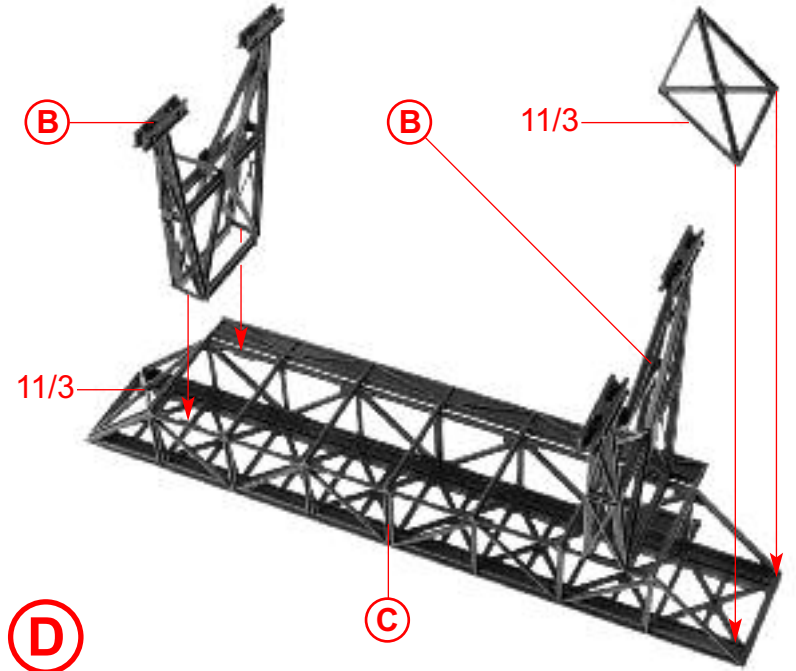

B

B

11/3

D

C

11/3

4

11/4

14/9

14/8

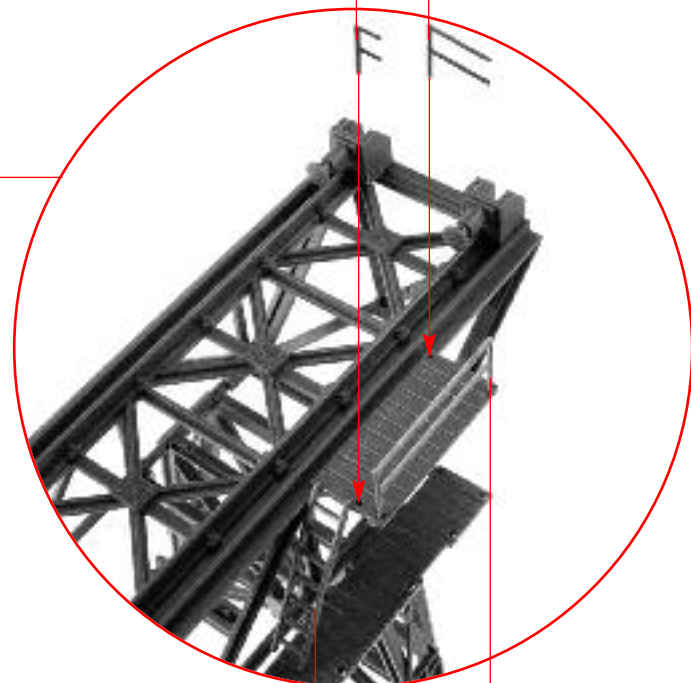
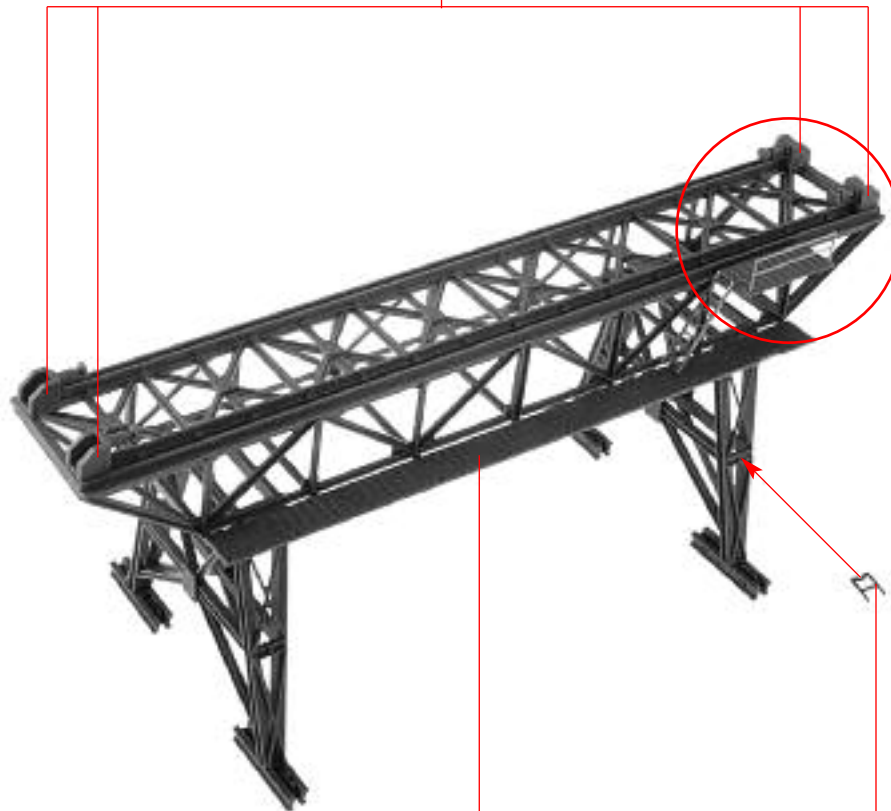

E

D

14/2

14/6

14/7

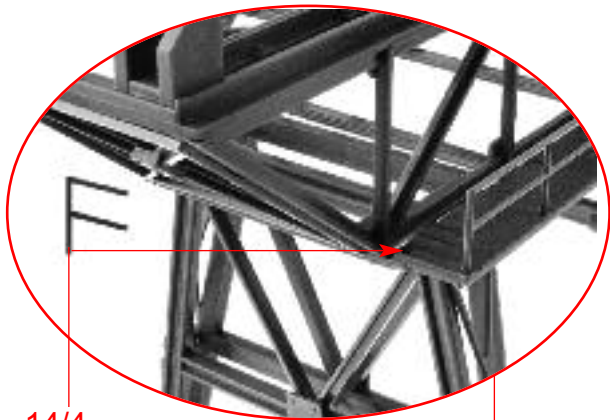

14/4

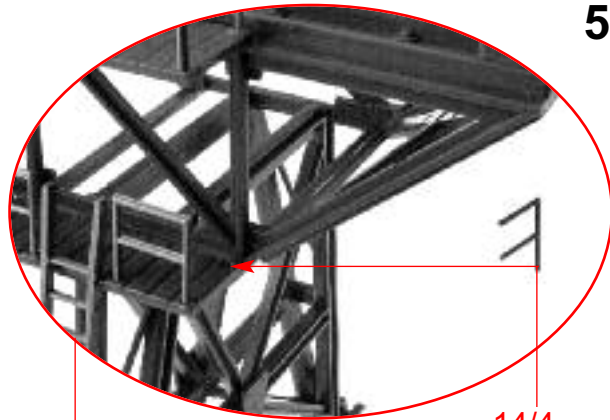

14/4

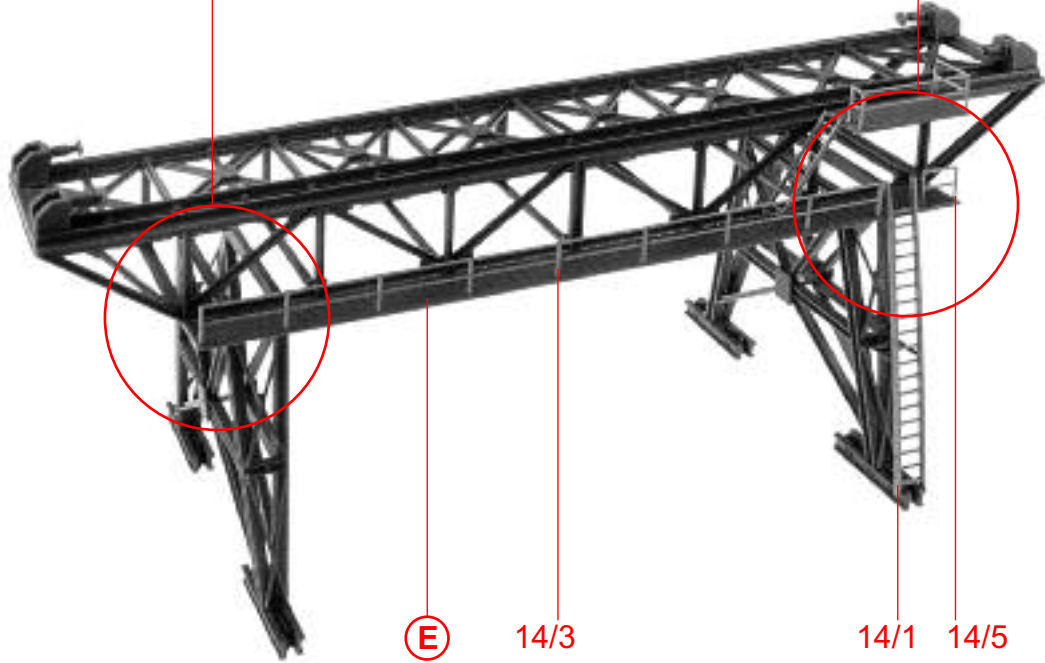

F

E

14/3

14/1

14/5

6

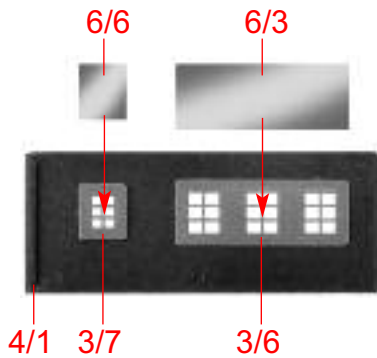

G

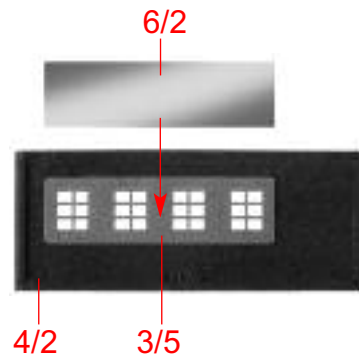

H

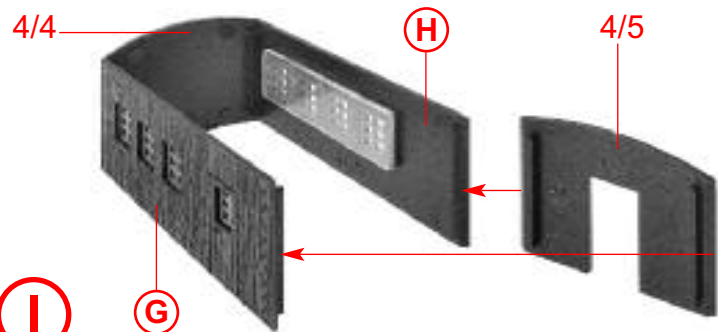

I

G

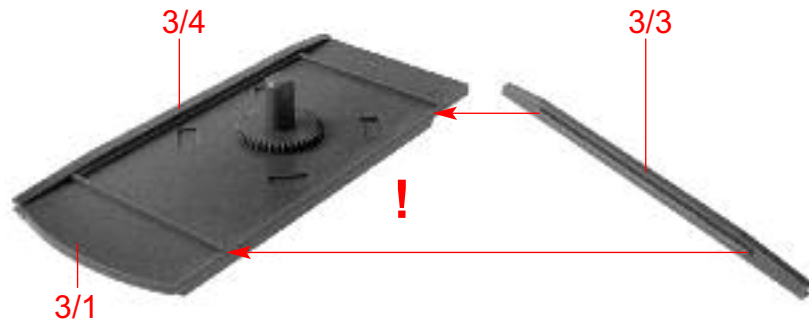

J

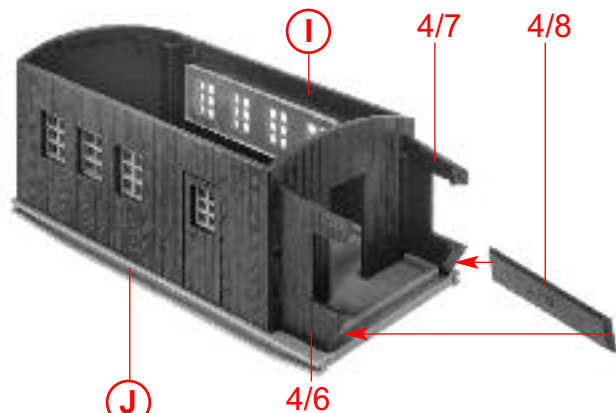

K

J

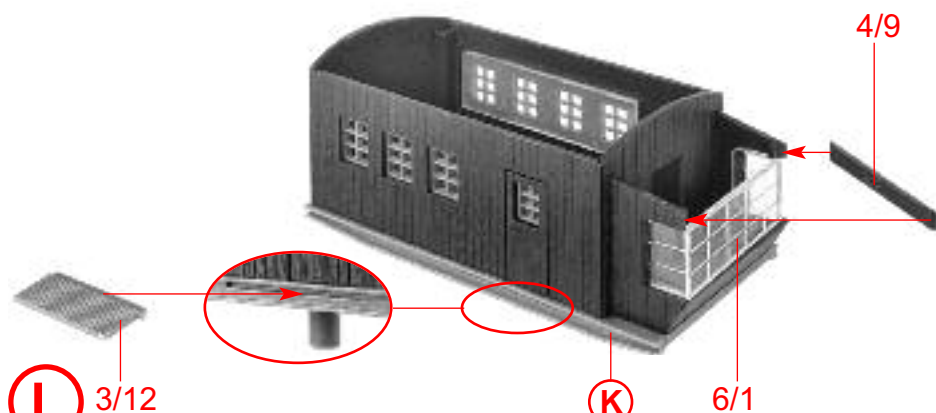

L

K

6/1

3/12

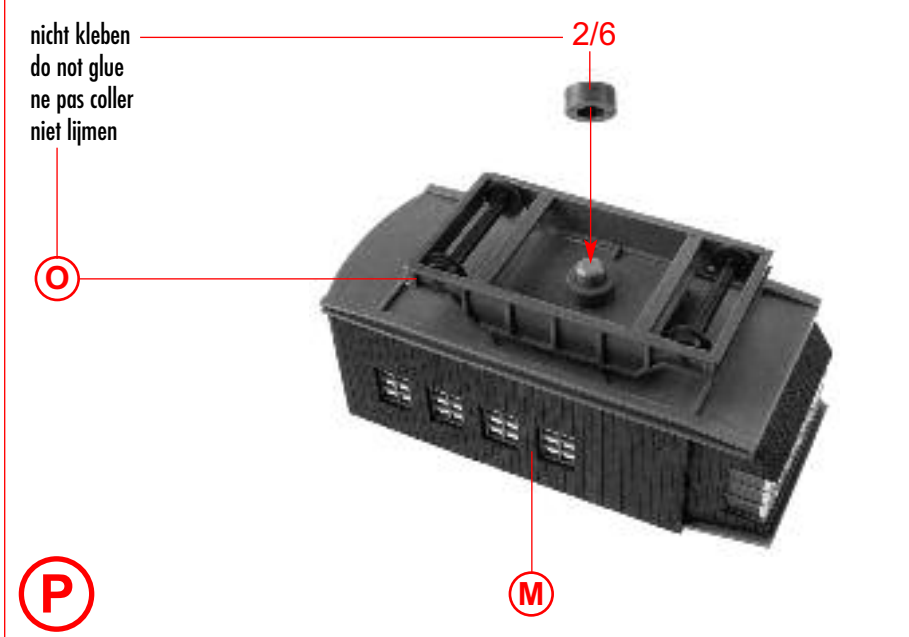
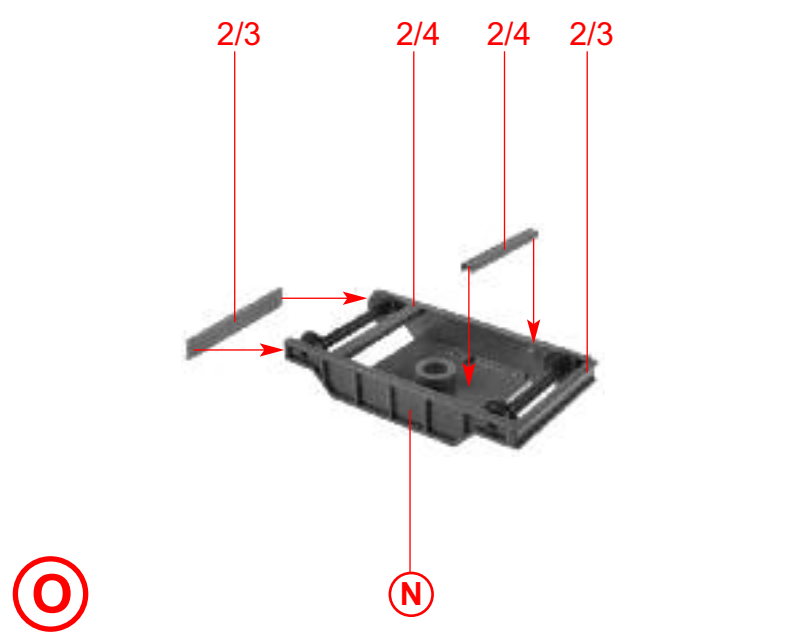
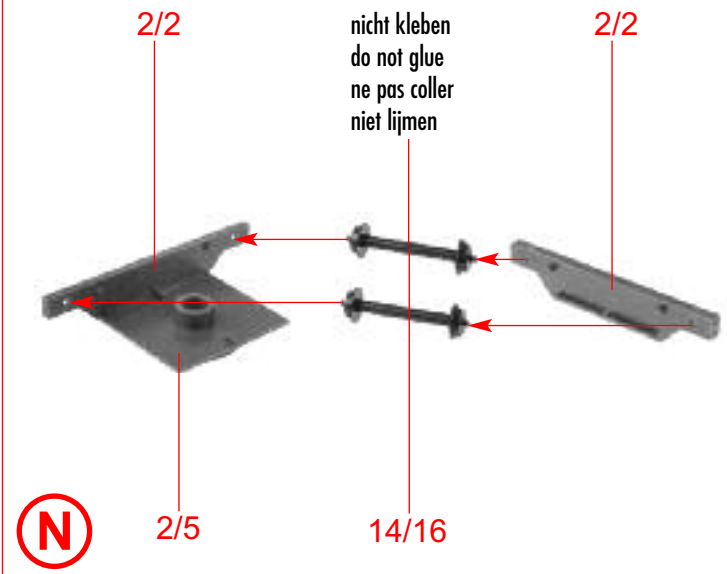
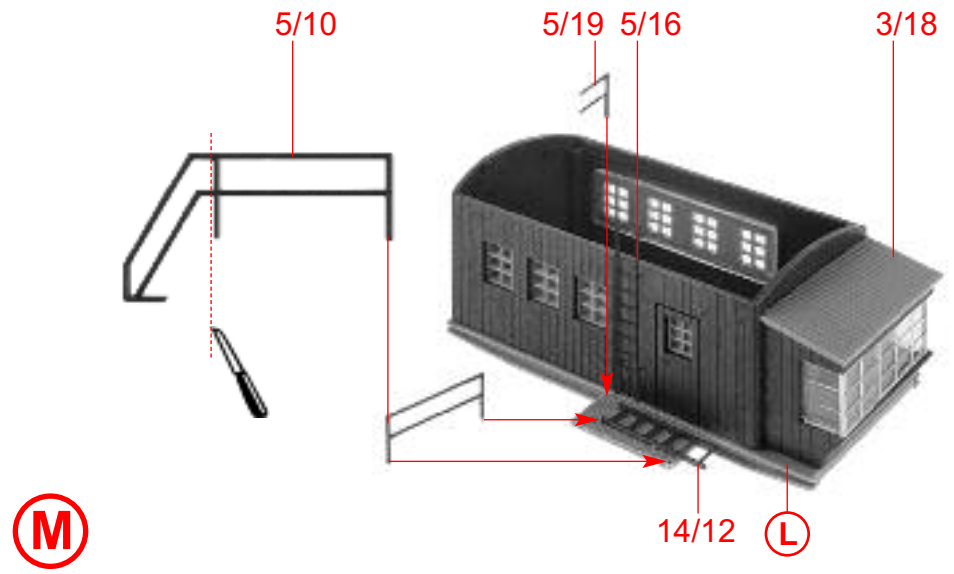

Durch den zusätzlichen Hafenkran-Ausleger erhöht sich das Kippmoment und bei rechtwinkliger Stellung der Brücke kippt der obere Aufbau von der Kranbrücke. Soll der Aufbau auf der Brücke frei verschiebbar sein, muss beim Bauabschnitt Q im hinteren Teil des Führerhauses ein Ballastgewicht (Steinchen, Sand, Blei etc.) gelegt werden. Bekommt der Kran eine feste Position, kann dieser auf die Schiene geklebt werden.

By the addition of the harbour crane jib, then the increased balance when set at right angles to the gantry, can cause the upper part of the crane to tip over. If the gantry be so constructed as to be freely moved along, then during construction of part Q a balance weight (small stones, sand, lead, etc.) should be inserted. If the crane is to be in a fixed position, then it can be glued to the rails.

Si vous désirez conserver sa mobilité à la partie supérieure de la grue, il convient lester l'arrière de l'abrie avec un poids: cailloux, sable, plomb, pour stabiliser l'installation. On aura intérêt à coller la grue au ballast, pour le cas où on ne prévoit pas de la déplacer.

Door de extra kraanarm kiept de bovenbouw vlog om, vooral wanner deze een haakse stand ten opzichte van de kraanbrug heft. Als de bovenbouw over de brug moet kunnen bewegen, moet bij bouwfase Q ballast (steentjes, zand, lood enz.) in het achterste deel van de cabine worden aangebracht. Indien de kraan permanent wordt opgesteld, kan deze op de rails worden gelijmd.

nicht kleben
do not glue
ne pas coller
niet lijmen

P

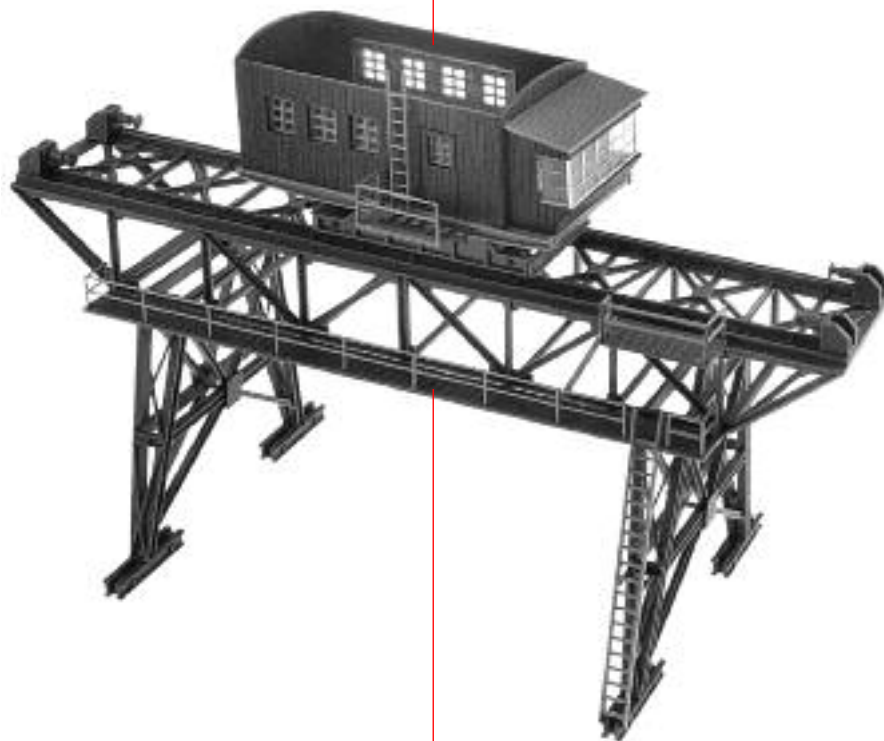

F

Q

R

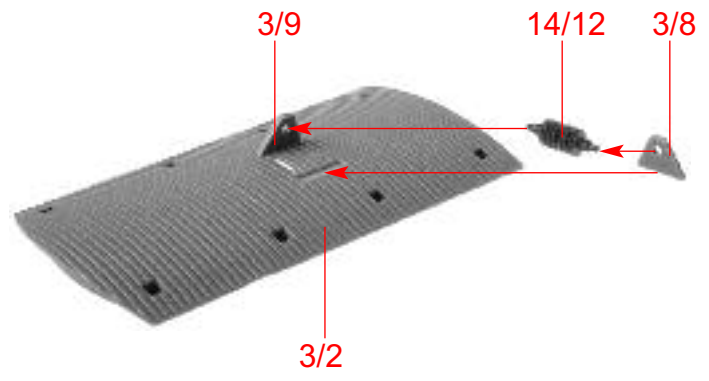

Variante I, II, III

S

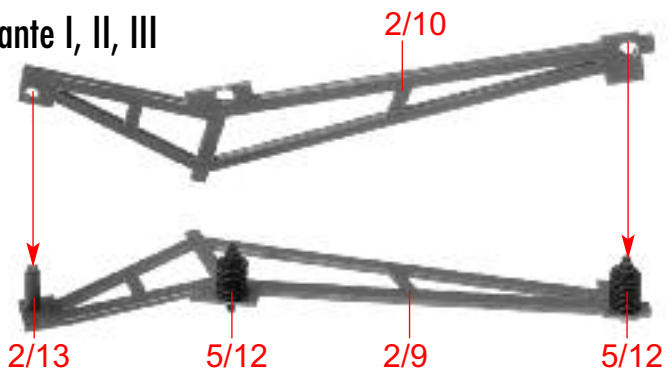

Variante I, II, III

T

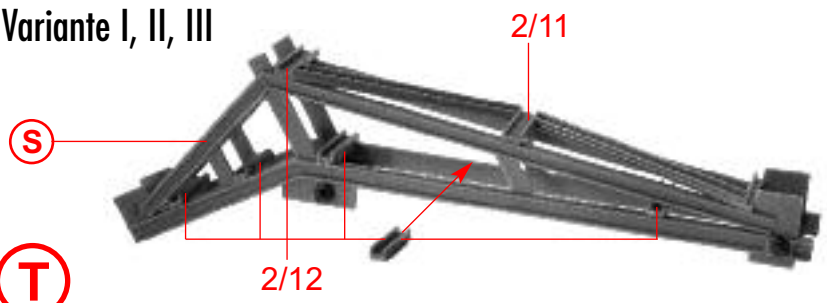

U

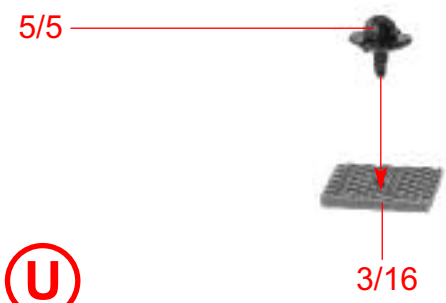

V

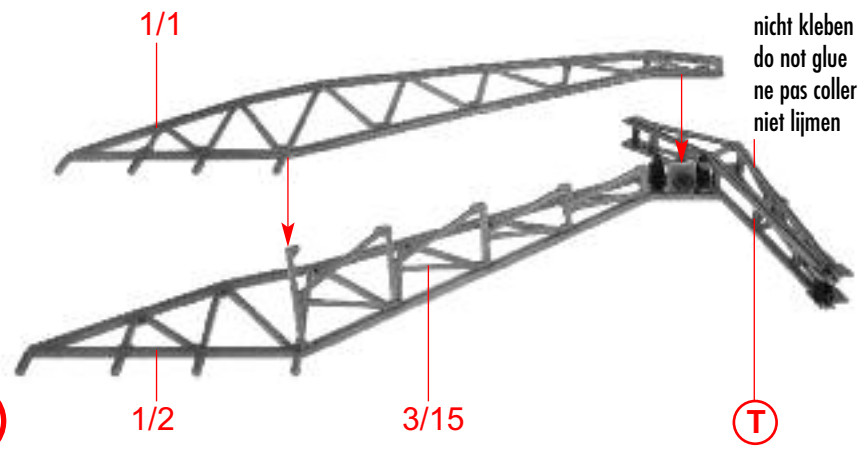

nicht kleben
do not glue
ne pas coller
niet lijmen

Variante I, II, III

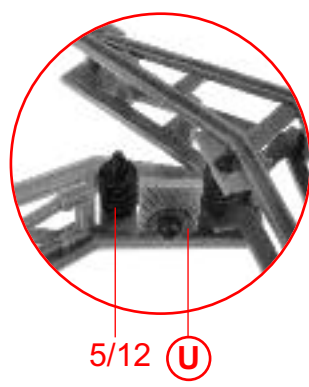

Variante IV

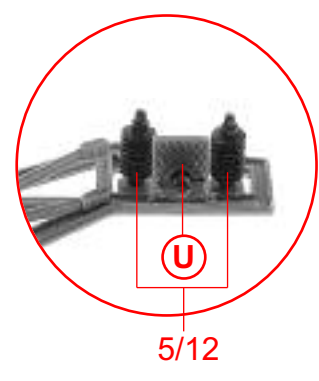

10 Variante I

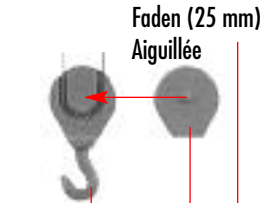

W 5/14 5/13

Variante II

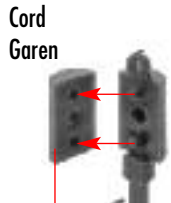

X 2/8 2/7

Variante III + IV

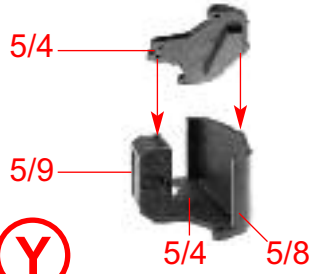

Y

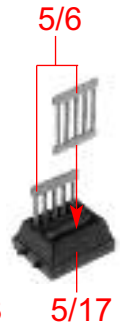

Faden (4 x 25 mm) Aiguillée
Cord Garen

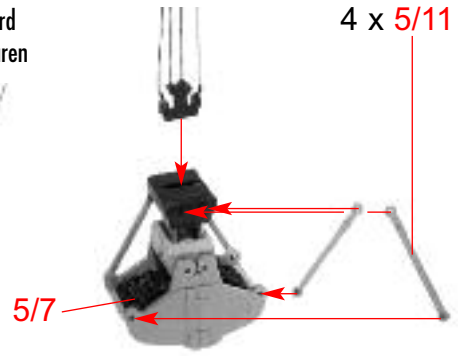

Variante I

Faden (20 mm) Aiguillée
Cord Garen

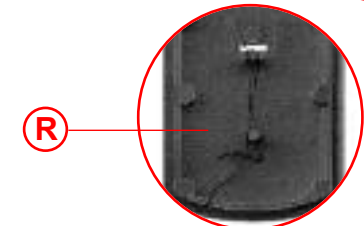
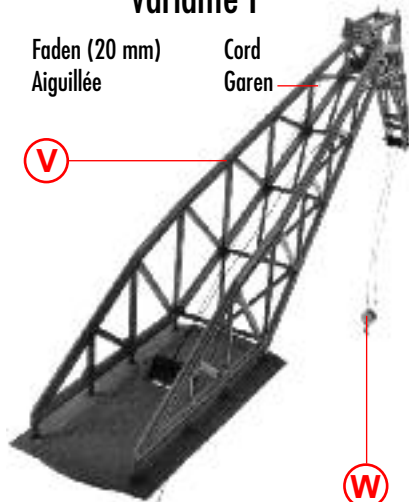

Z

Variante II

Faden (20 mm) Aiguillée
Cord Garen

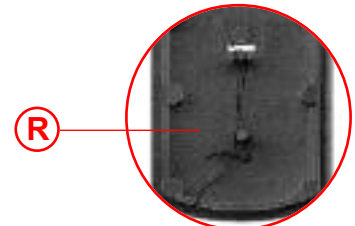
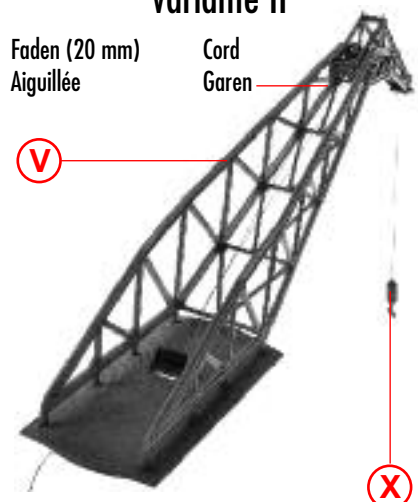

Variante III

Faden (20 mm) Aiguillée
Cord Garen

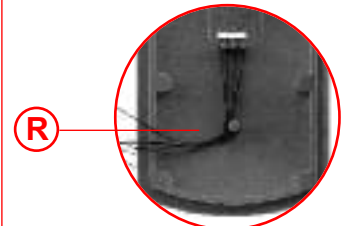
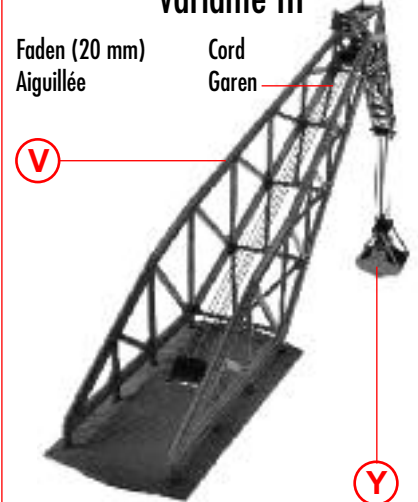

Variante IV

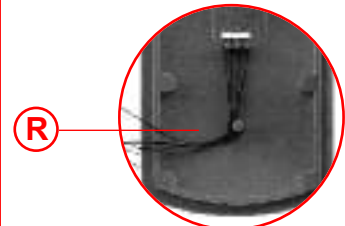

Faden verknoten und den Knoten mit Sekundenkleber fixieren!
Nouer le fil et renforcer le noeud avec une goutte de colle rapide!

Knot the thread and fix the thread with instand cement!
Draad vastknoten en de knoop met secondelijm fixeren!

Variante I, II, III

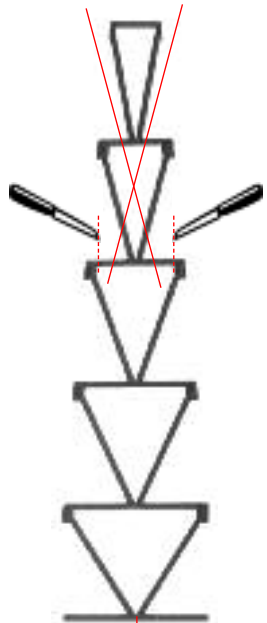

a 3/13

Variante I, II, III

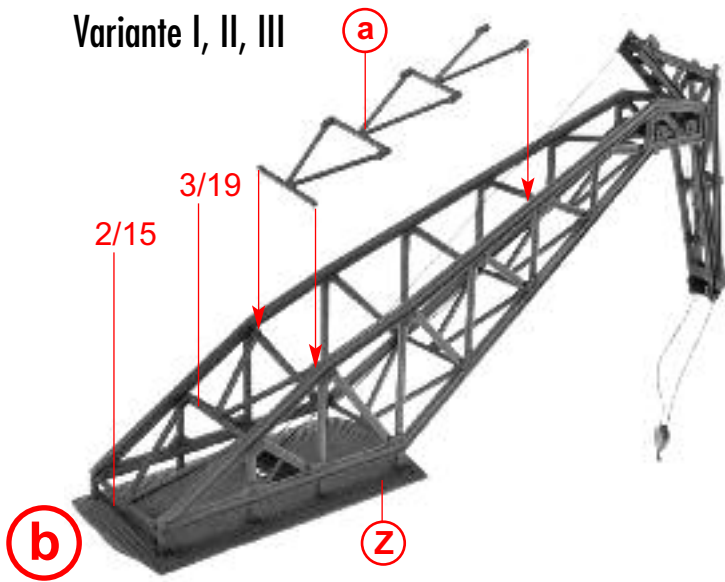

b

Variante IV

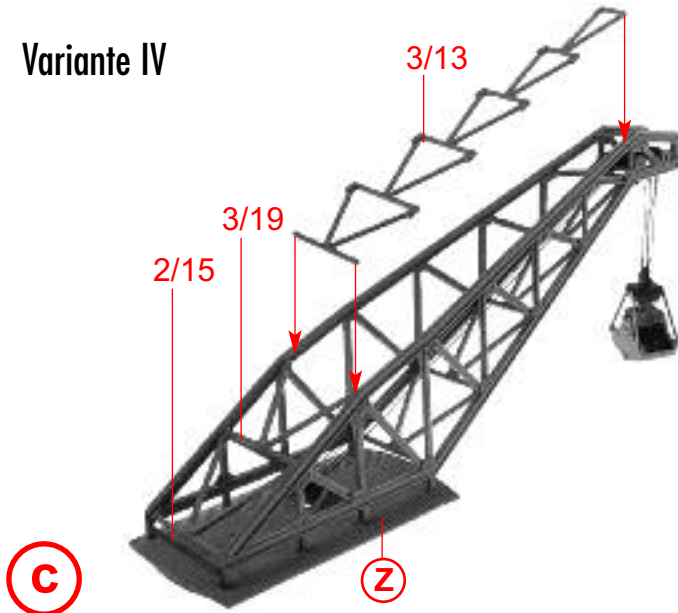

c

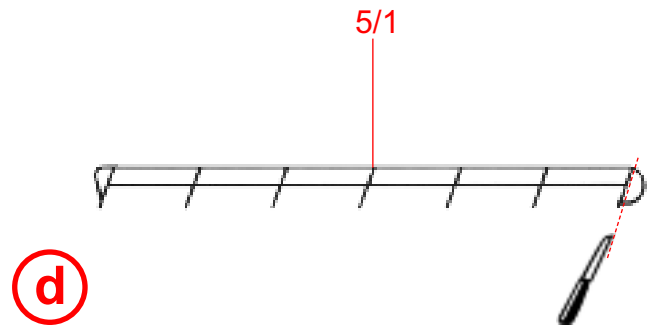

d

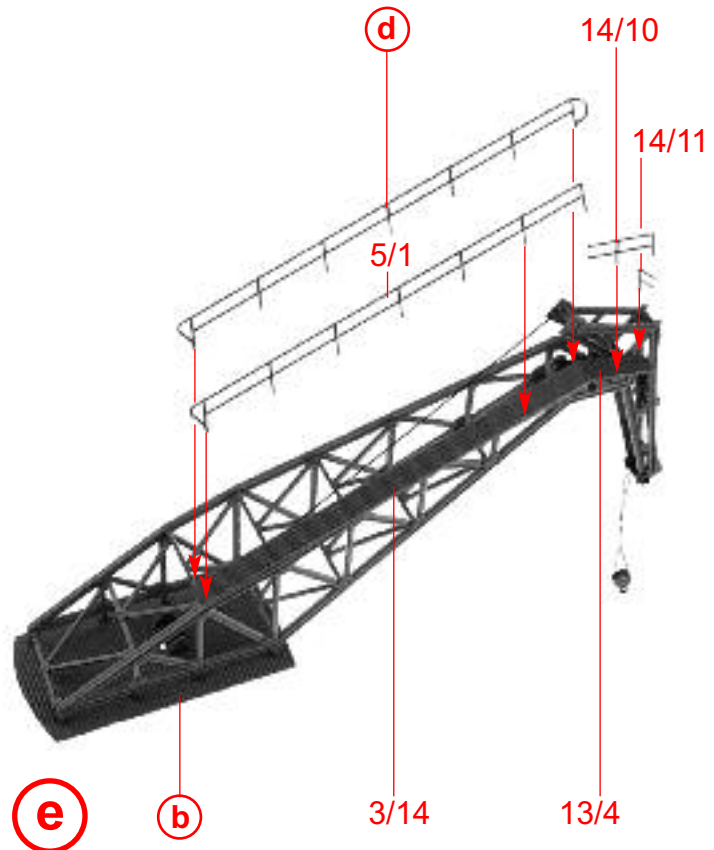

e

12

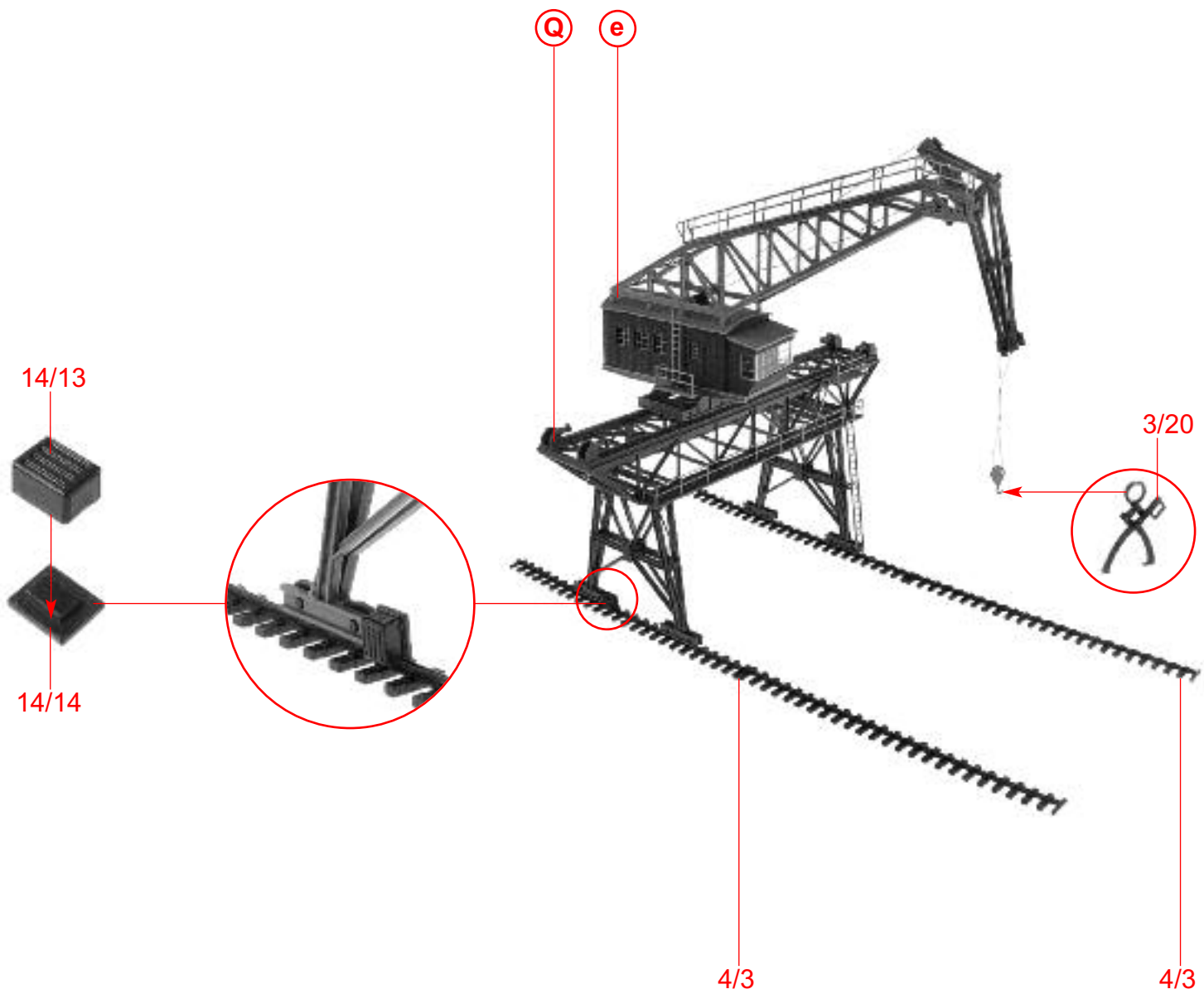

f