



Central Station

Table of Contents

1. Introduction.....	Pg.3
2. Basic Information for Using the Central Station....	Pg.3
2.1. Operation/ Function Elements.....	Pg.3
2.2. Installation.....	Pg.3
2.2.1. Installing/Changing Batteries.....	Pg.4
2.2.2. Setting up the Central Station.....	Pg.4
2.2.3. Connections to a Layout.....	Pg.4
2.2.4. Connections for a Programming Track	Pg.5
2.2.5. Direct Connections for a Mobile Station..	Pg.5
2.2.6. Connections for the 60125 Terminal....	Pg.5
2.2.7. Additional External Connections.....	Pg.5
3. Operation with the Central Station.....	Pg.6
3.1. Turning the Unit on/Initializing.....	Pg.6
3.2.1. Dividing up the Control Area.....	Pg.6
3.2.2. Operating the Touchscreen	Pg.6
3.2.3. How the Control Surface Works.....	Pg.6
3.2.4. Emergency Stop/ “STOP” Button.....	Pg.7
3.2.5. Release/ “GO” button.....	Pg.7
3.3. Operation Locomotives/ Trains.....	Pg.7
3.3.1. Setting up Mfx- Locomotives.....	Pg.7
3.3.2. Setting up Locomotives with Delta or Digital Decoders.....	Pg.7
3.3.3. Controlling a locomotive.....	Pg.9
3.3.4. Changing Locomotive Data.....	Pg.11
3.3.5. Deleting a locomotive from the Locomotive List.....	Pg.11
4. Controlling Accessories.....	Pg.12
4.1. Connections for Decoder.....	Pg.12
4.2. Setting up/ Editing Solenoid Accessories.....	Pg.12
4.3. Setting up a Control Area.....	Pg.13
4.4. Controlling Solenoid Accessories.....	Pg.13
4.5. Programming the 763xx Series Signals.....	Pg.14
5. Other Settings.....	Pg.14
6. Power Requirements.....	Pg.15
7. Additional Notes	Pg.15

1. Introduction

The third generation of Märklin multi-train control systems is now ready with Märklin Systems. The Central Station represents the most important component for this. It is responsible for generating the correct control data, it manages the coordination of the components connected to the system, and also offers an easy to use, manageable control surface. Trouble-free operation with this complex system is only guaranteed, when you use tested Märklin System components and nothing else. Any use of other makes of products with Märklin Systems will invalidate the manufacturer's warranty from Märklin. Damages arising from the use of other makes of products is therefore the responsibility of the operator.

When connecting the Central Station and other components to your layout, follow the techniques and principles contained in these instructions. The use of other circuits may easily lead to damage to the electronic components. It is best if you refrain from "expensive" experiments.

The Central Station is not a toy. Make sure that this unit is used by children only as a controller for model trains.

We hope and trust that you will have much enjoyment in the use of the Central Station on your model railroad layout.

Your Märklin Service Team

2. Basic Information for Using the Central Station

2.1. Operation / Function Elements

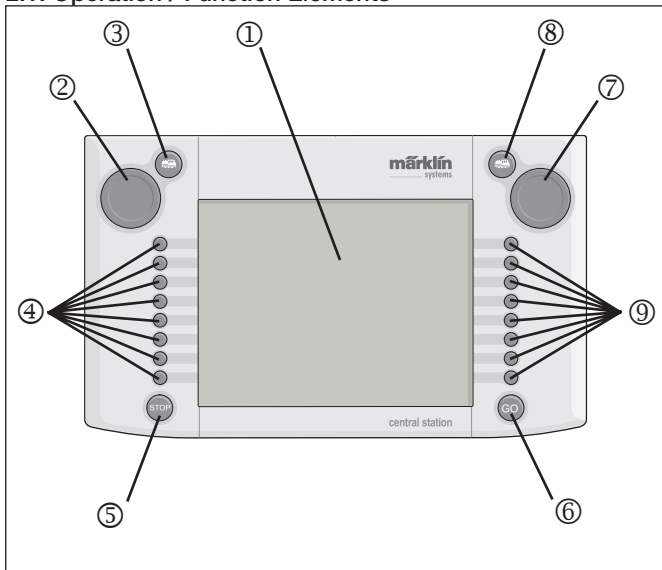

- 1 - Display with switching function (Touch Display)
- 2 - Locomotive Controller 1
- 3 - Button for "Locomotive" 1
- 4 - Auxiliary Functions 1
- 5 - "Stop" Button
- 6 - "Go" Button
- 7 - Locomotive Controller 2
- 8 - Button for "Locomotive" 2
- 9 - Auxiliary Functions 2

Contents as delivered from the factory:

- Central Station
- Stand
- Connecting cable to the connector box
- 2 connector plugs for direct connections to the track and programming track
- Connecting cable for a 6000/6001/6002/6003 transformer

2.2. Installation

- Use the Central Station only indoors in dry areas.
- Suitable transformer for power: Item nos. 60052 / 60055 transformer or their variants for other household power systems. The transformer is not included with the Central Station. The appropriate connecting cable comes with the 60052 / 60055. Using a no. 6000 / 6001 / 6002 or 6003 transformer will mean limitations on the maximum power output. The connecting cable required for the above comes with the Central Station.

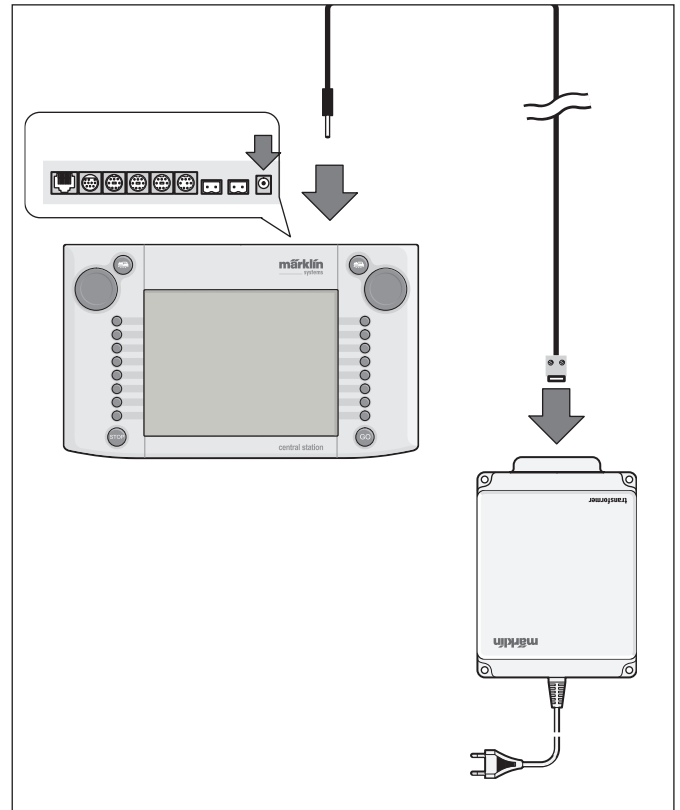

Caution: No other users such as turnouts, signals, lights, railroad grade crossing, etc. may be connected directly to the terminal clips for the transformer powering the Central Station! Users not receiving power through a digital decoder require a transformer separate from Märklin Systems!

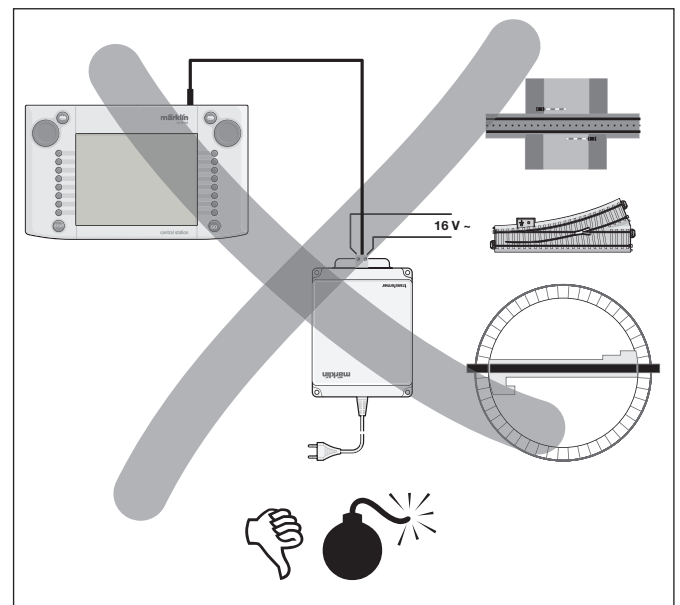

2.2.1. Installing / Changing Batteries

The battery's job: Storing the current train and accessory data for starting up the system again, after it has been turned off. Batteries are not included with the Central Station.

1. Remove the cover on the housing of the Central Station for the battery holder.
2. Batteries to use. Only 1.5 volt batteries (AAA size, diameter = 10.5 mm x 44.5 mm / 7/16" x 1-3/4"). Rechargeable batteries are not suitable! Pay attention to the polarity and the markings in the battery holder when installing the batteries ("+" and "-").
3. Put the cover back on. If you like it, you can fix the cover with the included screw.

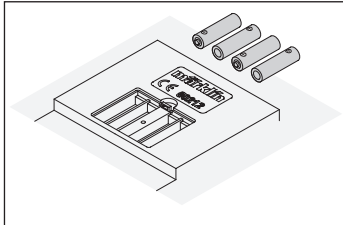
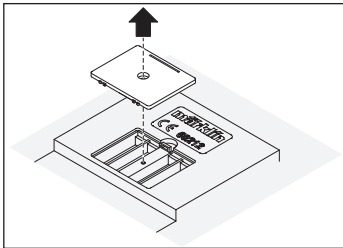

- Use only high quality batteries (example: alkaline batteries).
- Do not remove the batteries until the Central Station is turned off.
- If the Central Station is not going to be used for a long period of time, then the batteries should be removed. (to protect against the batteries leaking)
- If your batteries are weak or totally run down, a warning symbol will appear in the lower right and left corners of the screen.

Caution! Never attempt to recharge batteries! Doing so involves the danger of injury and fire!



Batteries Do Not Belong in Your Garbage Container!

Every user in the European Community is obliged by law to turn in used batteries at a collection point in his community or at the dealer from whom he purchased the batteries. The batteries will then be taken to an environmentally recycling point.



Batteries containing hazardous materials are marked with this symbol and with chemical symbols (Cd = cadmium, Hg = mercury, Pb = lead).

2.2.2. Setting Up the Central Station

Mount the Central Station on its stand. Make sure when doing this that the Central Station is securely in place with the snap-in connection on the back between it and the stand. The angle of the Central Station on its stand can be adjusted.

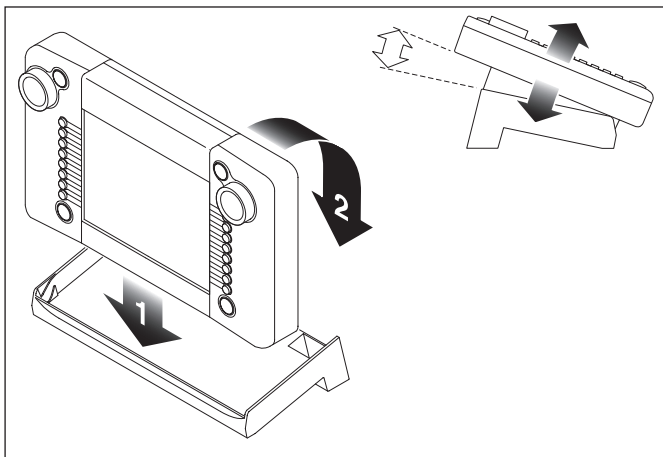

2.2.3. Connections to a Layout

1. Make sure that the power cord for the Central Station's transformer is unplugged from the household current.
2. Install the connecting cable between the transformer and the

- Central Station.
3. Connect the feeder wires to the layout.

2 alternatives:

- a. Connection through a connector box (24088 for H0 C Track, 60115

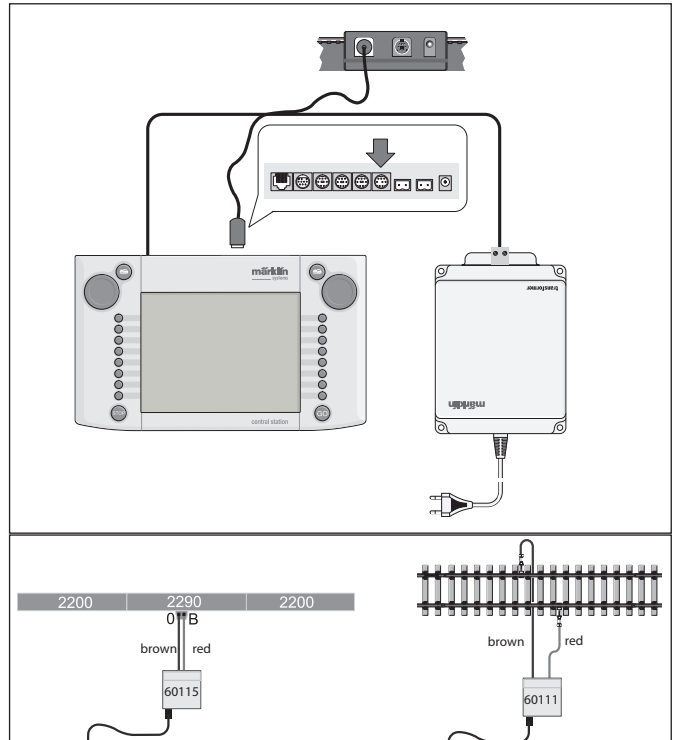

for H0, 60111 for 1 Gauge)



Caution: Never connect the transformer for the Central Station to the connector box!

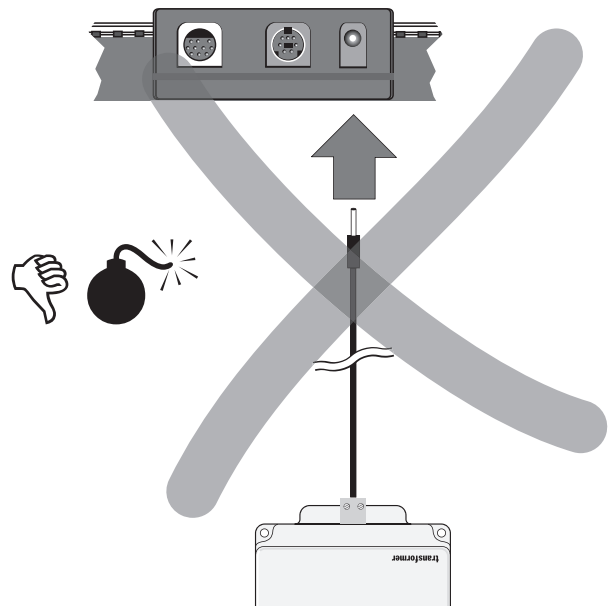

- b. Direct Connections

Connections with the plugs (611 719) included with the Central Station and the following connecting hardware specific to the individual track systems:

- A: 74040 feeder wire set + any standard section of track. The 74046 may not be used.
- K: Red and brown wire (7105, 7102 with a wire cross section of 0.19 sq. mm / 0.0003 sq. in. or red and brown wire from the 71060 wire assortment with a wire cross section of 0.75 sq. mm / 0.001 sq. in.) + a 2290 feeder track. Do not use the 2292 feeder track.

M: Red and brown wire (same specifications as for K Track) + a 5111 feeder track. Do not use the 5131 feeder track.
 1 Gauge: 5654 feeder wire set + any standard section of track.

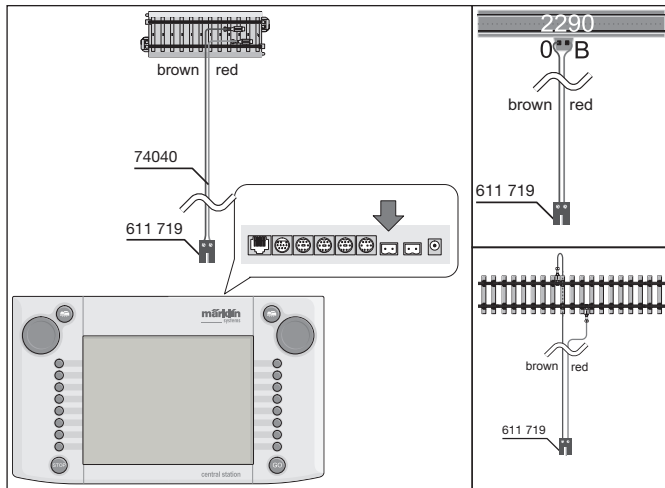

4. On large layouts feeder wires must be installed at least every 2 meters / 78".

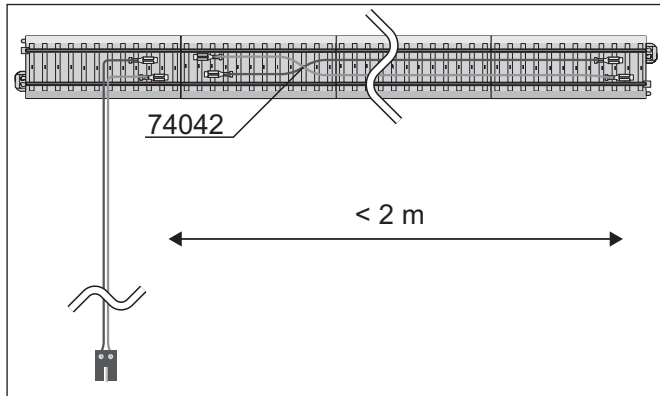

2.2.4. Connections for a Programming Track

The Central Station has a second set of connections with a smaller power output (max. current 1 amp), which is used for a programming track.

This set of connections has the same type of sockets as for the connections to the layout. The same notes as in Section 2.2.3 apply here for the connecting hardware for the different track systems.

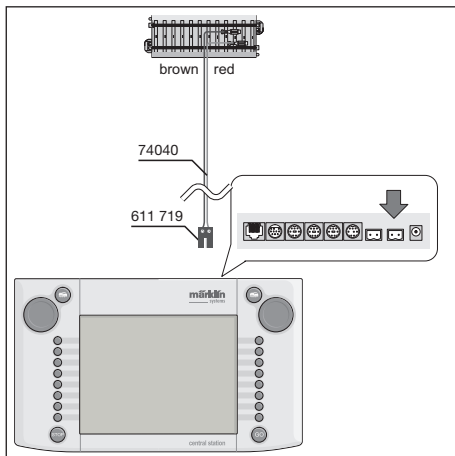

- Set up the programming track as a separate track.
- Only 1 locomotive or powered unit may be on the programming track at a time.
- After you have finished programming a locomotive or powered unit, remove it immediately from the programming track. The Central Station sends data in many operating states to the programming track during normal operation (example: when a new locomotive is being set up in the locomotive list). Locomotives "parked" on the programming track can possibly be reprogrammed unintentionally as a result.

2.2.5. Direct Connections for a Mobile Station

The Central Station offers the option of having 1 Mobile Station connected to it directly as an auxiliary locomotive controller. Additional Mobile Stations can be connected to the Systems network by means of the 60125 Terminal. The connection socket for the Mobile Station on the rear of the Central Station can be selected from one of three alternatives. If additional Mobile Stations are connected to these free sockets, they will be free from damages. In this situation, however, adherence to your local regulations for preventing interference with television and radio reception cannot be guaranteed. This type of connection may therefore not be done.

Important: In any event the adapter cable (10 to 7 pin) must be used. This adapter cable comes with the Mobile Station listed under item no. 60652 or is available as a spare part under item no. 610 479 at your authorized Märklin Systems dealer.

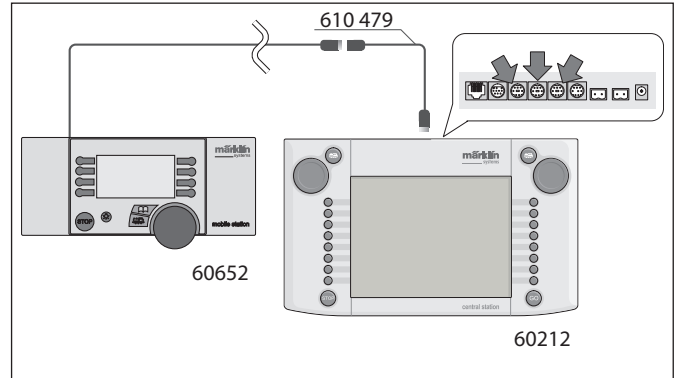

- When the Mobile Station is connected to the Central Station for the first time, the Central Station checks the version of the database in the Mobile Station. If this version is older than the version in the Central Station, then this database is automatically updated. The screen on the Mobile Station will go dark during this process. A note about the updating process will appear after a short while on the Central Station's screen. After the updating of the database in the Mobile Station is finished, the latter will also be reset. All of the data in the Mobile Station's locomotive will be erased in the process!
- When the Central Station is connected to the layout by means of a connector box, an additional Mobile Station can also be connected to this unit. The 610 479 adapter cable is also required for this.

2.2.6. Connections for the 60125 Terminal

The 60125 Terminal is used to set up a Systems network. Systems components such as the Mobile Station can be connected to a Terminal. When several Terminals are used, they are connected one behind the other in series. The connecting cable for the Terminal (about 60 cm / 24" in length) can be lengthened with the 60126 extension cable (about 200 cm / 79" in length) to allow flexibility in the location of the next Terminal.

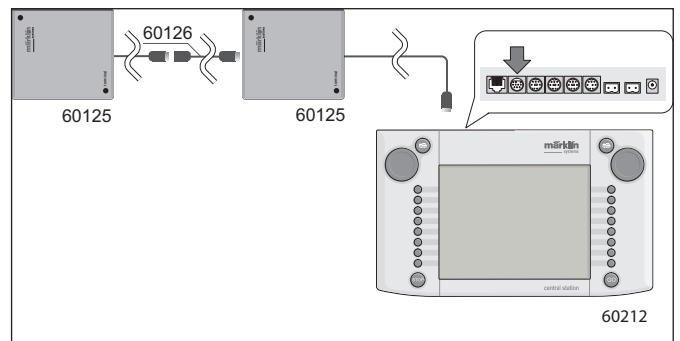

2.2.7 Additional External Connections

Your Central Station has another connection, which will be used in the future for updates of its software from a personal computer. This connection can be used as soon as the software is offered. Without the appropriate software, no cable or unit of any kind should be connected to this socket, even for testing.

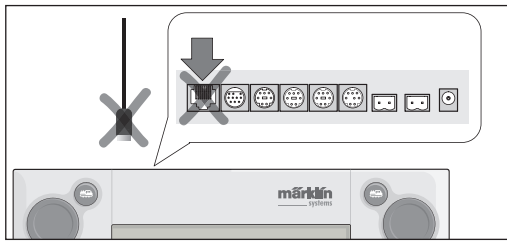

Caution! When you remove the connecting cable to a personal computer, you must first press down on the snap-in tab before pulling the cable out of the socket. This is, however, located under the base of the Central Station. You should therefore loosen this snap-in connection carefully, for example, with a flat blade screwdriver.

3. Operations with the Central Station

3.1. Turning the Unit on / Initializing

The unit must be set up as described in Chapter 2, taking into account the particular features of your model railroad layout (type of track, etc.). Now plug the power cord for the Central Station's transformer into the wall outlet.

Caution: Make absolutely sure that the transformer is also suitable for your household current. You can find the specifications for the transformer on a plate on the underside of the transformer.
For example:
Transformer 60 VA (60052): 230 V~/50 Hz (230 volts AC / 50 Hertz)
Transformer 60 VA (60055): 120 V~/60 Hz (120 volts AC / 60 Hertz)

Caution: Märklin transformers may only be used indoors in dry areas.
The Central Station can only be used outdoors (for example, for a 1 Gauge garden railway), if it is protected against moisture and extreme temperatures. In this situation the Central Station must be brought indoors when you are through operating the garden railway outdoors. The Central Station may not be exposed to rain, direct sunlight or temperatures under 10° Centigrade / 50° Fahrenheit or over 30° Centigrade / 86° Fahrenheit.

Tip: Use a power strip with an on/off switch for the power cords on the transformers in the system, so that you have a common on/off switch for all of the components. This power strip should also have protection against voltage spikes and voltage surges to protect the Central Station against voltage spikes from lightning strikes.

The Central Station starts its so-called initialization phase as soon as the transformer is supplying the Central Station with sufficient power. Depending on the quantity of data to be set up, this phase may last longer than 1 to 2 minutes. The process of the initialization phase is documented after a few seconds by the lighting for the screen coming on and shortly after that by a square moving back and forth in the lower area of the screen.



Note: The first time you turn the Central Station on, the initialization phase may last somewhat longer. The lighting for the screen may go off during this process. It will come back on automatically at the end of the initialization phase.

3.2.1. Dividing up the Control Area

- 1 = Button for settings on the left controller
- 2 = Button for setting up solenoid accessories
- 3 = Button for setting up accessory controller / functions
- 4 = Button for setting basic settings on the Central Station
- 5 = Button for settings on the right controller
- 6 = Warning Indicator for Weak or Run Down Batteries

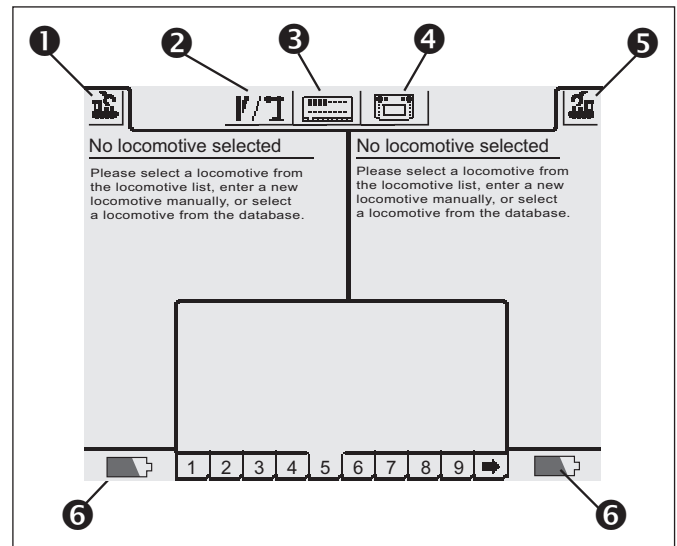

3.2.2. Operating the Touch Screen

The Central Station has a Touch Screen (a screen that reacts to being touched). By simply touching the screen above a symbol shown there, a desired action will be carried out.

Example: A field with a picture of the Central Station can be found in the upper operating menu bar for the Central Station. If you touch this field with your finger, a new field with various setting options for the operation of the Central Station will be opened.



Pay attention to the following when working with the touch screen:

- Touch the screen only to operate accessories. Never press hard on the screen.
- Never lean on the screen.
- Other things such as a plastic stylus can be used in addition to your finger to control things on the touch screen. Caution! The wrong material can cause scratches on the surface of the screen. For that reason do not use pointed objects. The plastic stylus used for pocket computers would be suitable and they are available in computer stores as a replacement part.

3.2.3. How the Control Surface Works

The Central Station has a locomotive list and a solenoid accessory list, in which all locomotives, turnouts, signals, etc. are set up, which you want to control on your layout. These entries are the personal identification for these items. You cannot operate them without this "personal identification". These data must therefore be set up first.

This process of setting up the identification takes place totally automatically (with mfx locomotives) or is manually supported with an easy to use menu technology. The entries can be supplemented, changed or deleted at any time. They serve not only as the foundation for the Central Station, but for all Märklin Systems control units connected directly or indirectly to the Central Station. If you have connected the 6021 Control Unit central unit by means of an adapter, this unit, including all control units connected to it, cannot in principle access these data.

The accessory controller on the Central Station consists of 18 control fields on which up to 16 of the solenoid accessories already defined can be placed. The individual solenoid accessories can also be used on several control fields.

The two locomotive controllers also take the data from the locomotive list for the locomotive that is to be controlled.
Tip: To call up a new locomotive, it is first selected from the locomotive list. The more extensive this list is, the longer it takes to select the entry in the locomotive list. We therefore recommend that you check the locomotive list on a regular basis for entries, which are no longer required.

The maximum number of entries in the locomotive list depends on different factors. The upper limit is several thousand entries, which is well over the number you would find necessary in practice.

3.2.4. Emergency Stop / „STOP“ Button

Pressing the “STOP” Button:

The electrical power for the layout and for the programming track is turned off. Boosters or other power units connected to the system also shut off. The red light in the “STOP” button comes on. When there is an overload, the Central Station automatically switches to this mode.

Ending this condition:

1. Find and correct any short circuit or cause for the overload.
2. Press the “GO” button. (=> 3.2.5)

Note: When you have pushed the emergency stop button, changes for the commands to the locomotives and solenoid accessories can still be entered on the Central Station. These new commands are not carried out until the layout is again supplied with power.

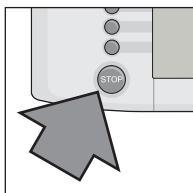

When the STOP status is activated by a short circuit, a short circuit symbol will appear for several seconds in the lower left and right corners of the screen. After that the not “EMERGENCY STOP” will appear there, just as if you had pressed the “STOP” button.



3.2.5. Release / “GO” button

The “GO” button is pressed to resume operations again on a layout, when the power to it has been shut off (emergency stop). When the green light goes on in the “GO” button, the red light in the “STOP” button is turned off. Voltage is now available again at the layout outputs on the Central Station.

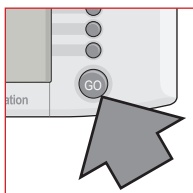

Note: If the Central Station immediately goes back into the emergency stop mode (the red light in the “STOP” button lights up) on its own, then usually there is a short circuit on the layout. This must be corrected before operations can be resumed on the layout.

3.3. Operating Locomotives / Trains

3.3.1. Setting up Mfx Locomotives

Generally, mfx locomotives register themselves on the Central Station. All you have to do is place the locomotive on the track. Make sure when doing this that the layout has power flowing to it (release mode). The locomotive may not be initially placed in an area of the track that is not continuously supplied with electrical power (examples: signal block, storage siding where you can turn the power off, etc.) or an area of the layout that is connected through the Connect 6017 unit (item no. 60129) to a 6015 or 6017 Booster. The transfer of data from the mfx locomotive to the Central Station and reverse takes about 1 minute. If the mfx locomotive is placed on the layout for the first time, while the latter is in the middle of ongoing operations, then the registration process may take up 3 minutes.



Two mfx symbols will appear in the upper menu list on the screen while an mfx locomotive is being registered. These symbols report the progress of the registration process. When these symbols are completely filled in with black, you must press on one of the two symbols. The newly registered locomotive is taken into the locomotive controller to which you have assigned it, and it is also taken into the locomotive list at the same time.

Mfx locomotives can only be registered one after the other the first time out. The registration process for another locomotive cannot take place until the first locomotive is completely registered.

Tip: Place locomotives to be registered one after the other on the layout. If several locomotives to be registered are on the track at the same time, the complete process can take considerably longer to complete.

3.3.2. Setting up Locomotives with Delta or Digital Decoders

The Central Station is also able to control the different Märklin Delta or Digital decoder generations, which are designed for operation with Märklin Delta or Märklin Digital (both the 6020 Central Unit and the 6021 Control Unit and their variants).

The following steps can be done on the right or the left side of the train controls on the Central Station. The operation steps on the left side of the train controls are demonstrated by way of example.

Press the menu button in the upper left corner of the display screen. A selection menu will appear on the display screen next to this button. The arrow in the line “New Locomotive” indicates that additional selection menus can be opened by selecting these lines. There are two different ways to select the different submenus:

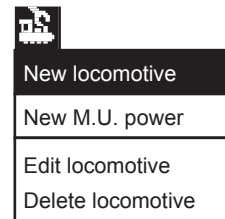

- a: Direct selection by touching the screen at the line of text in question.
- b: By turning the left control knob on the Central Station. The black cursor bar will then wander from line to line. The submenu on which the black cursor bar is now standing is activated by pressing on the control knob.

Select the line “New Locomotive” and activate the submenu. Two new selection fields will appear, “enter manually” and “from database”.

Enter manually - The entry in the locomotive list (name, address, etc.) is generated completely by you the operator.

From database - The locomotive data is generated by going into a database integrated into the Central Station. This database has factory data for many of the earlier Märklin models.

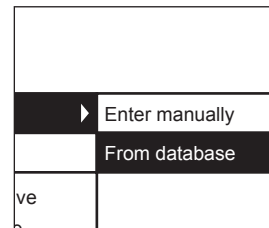

Variation 1: From database
Select the line “from database” either with the control knob or by directly touching the screen. A menu with different entries from the integrated database will appear.

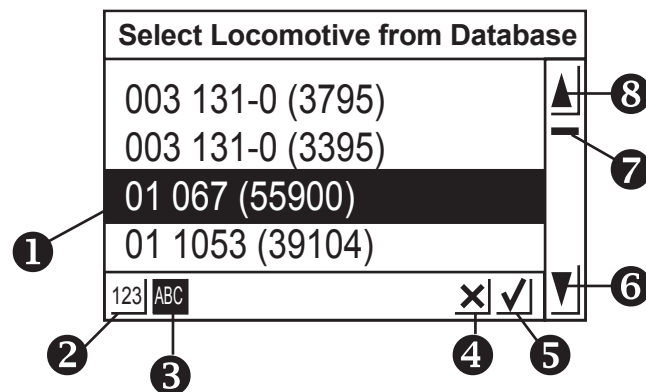

- 1 = Locomotive selected
- 2 = Data lines sorted by item number
- 3 = Data lines sorted by name
- 4 = End without selecting a locomotive
- 5 = Select current data line
- 6 = Go down one data line
- 7 = Position indicator for the entire list
- 8 = Go up one data line

Selecting a data line:
Select the desired locomotive by moving the selection bar cursor (1) up and down by turning the control knob and then pressing down on the control knob.

Or, the data line list can be navigated by pressing on the arrow buttons (6 or 8). The data line you want will be selected by touching the check mark field (5). The process can be ended without selecting a locomotive by touching the “x” field (4).

Locomotives in the database can be sorted with two different criteria. Either by the Märklin item number (touch button 2) or by the name suggested by Märklin (touch button 3). Tip: The factory often assigns names from the class number or from a well known nickname for the prototype.

If you press the first letter or number on the keypad depicted in the lower part of the screen, the display for the data line that begins with this letter or number will appear.

Example: The list is sorted by names. If you press on the key for "8", the class 80 will appear from the different data lines, since it is the first data line that begins with the number "8".

After the data line has been selected, it is taken directly into the locomotive controller part of the Central Station. If you want to edit locomotive data such as the name, function button assignment, or the address, etc., please read the notes in section 3.3.4.

Note: In contrast to the Mobile Station the Central Station will accept several entries in the locomotive list with the same address! No locomotives with the same identical address can be controlled simultaneously. A message to this effect will be shown on the locomotive controller part of the screen. This also holds true for locomotives with a consecutive address (model with two addresses).

1 - 80

Variation 2: Entering manually

After you have selected this menu, an entry field will appear in which you can give different types of locomotive data. A keyboard is located under the entry field to facilitate the entry of texts. The following settings can be made:

Decoder

Setting the type of decoder. Standard practice is that "Märklin Motorola 14" or "Function Decoder" are the only variations that can currently be set. "Function Decoder" includes the function decoders that can be controlled with the first central unit, the 6020 Central Unit. Examples of these are the 4998, 4999, or 49960 working cars, the 7651 rotary crane, or the 58115 1 Gauge car. The function decoders (examples: 60960 or 60961) or working models based on the same technology, models that can only be controlled with the 6021 Control Unit 6021, must be set up on the Central Station with "Märklin Motorola 14" as a type.

Address

The address can be set between 1 and 80 for locomotives.

Ways to set addresses:

1. Touch the "Address" field. Then change the value of the address by turning the control knob.
2. Change the value of the address with the "-" and "+" fields to the left and right of the address display.
3. Touch the "Address" field. Delete the value with the "<" button (upper right on the keyboard) and enter the new address between 1 and 80 with the numbers on the keyboard. The addresses 1 through 9 are entered as single digits. If you try to enter addresses above 80 or below 1, you will get an error message.

Name

By touching the "Name" field on the screen you can then enter a designation for the locomotive in the entry field next to the "Name" field by using the keyboard. This designation will then always appear on the part of the screen for the locomotive controller, when you

call up the locomotive. The name can consist of a maximum of 16 characters.

Note: If you don't make an entry in this field, the preset designation "New" will appear as the name. The Central Station does not check whether the name has already been taken.

Locomotive Symbol

You can use this selection field to select an appropriate symbol for a new locomotive you are setting up in the Central Station. To do this, touch the locomotive symbol depicted or the arrow positioned to the right of it you're your finger. A larger selection field will appear in which you can select a suitable element by again either touching the desired element, by turning the control knob and then pressing on it or by touching the check mark field to the right under the selection field or by scrolling up and down in the column on the right.

Note: An incorrect symbol has no effect on locomotive operations. The symbol can be changed later at any time.

Adding a Locomotive to Your Favorites List

A locomotive you run frequently can be found more easily in an extensive motive power list by integrating the locomotive into a favorites list. This entry in the favorites list can be used as a sort criterion, when you call the locomotive up later. There is a selection field in front of the text "Add locomotive to favorites list". The assignment of a locomotive to the favorites list is indicated by touching this selection field. A check mark by the locomotive indicates that this locomotive is in the favorites list.

The data line with the settings you have just made is accepted by touching the confirmation area with the check mark below and to the right in the selection window. By touching the end field with the "X", you leave this submenu without accepting the locomotive data. The same holds true, when the locomotive controller area of the screen in the upper left corner is touched.

Advanced

Still another entry field is located behind the "enter new locomotive" entry field. This new field is designated on the upper edge with "Advanced". Touching this "Advanced" field brings the entry field to the front and the "enter new locomotive" field is put in the background.

Up to 6 additional fields for setting values can be called up in this "Advanced" submenu. Whether these fields are used depends on the type of decoder used in the locomotive.

1 = Analog Settings

In this instance the following parameters can be set for certain decoders:

Analog mode activated: determining whether the locomotive can be operated with analog controls.

Starting voltage: determining the voltage level in the first speed level.

Maximum speed: determining the maximum speed at the maximum running voltage

2 = Locomotive Running Characteristics Settings

In this instance the following parameters can be set for certain decoders:

Reverse operation: The forward and reverse direction of travel can be swapped on the locomotive.

Vmax: Setting the maximum speed in the highest speed level.

Vmin: Setting the speed in the lowest speed level.

Acceleration rate: Setting the amount of acceleration delay.

Braking rate: Setting the amount of braking delay.

Trim for forward operation: Setting the magnitude of the effect that the different control settings have on forward operation.

Trim for rearward operation: Setting the magnitude of the effect that the different control settings have on rearward operation.

3 = Motor Settings

In this instance the following parameters can be set for certain decoders:

Motor Pulse Width Modulation (can motors with iron-free cores) frequency: Setting for the frequency used to control the motor. 2 alternatives for setting the frequency (low or high frequency).
Tip: The high frequency is preferred for most motors.

Settings for load compensation:

Control reference: Adjustment for agreement with the feedback values sent back from the motor.

Control parameter K: Determining the degree of control.

Control parameter I: Setting to the motor's inertia. High inertia (motor with a large flywheel) requires a low value.

Control influence: Determines the degree of effectiveness of the control.

Steady state characteristic for speed: Determines the distribution of the individual speed levels (progressive, linear, regressive, etc.). The different variations are shown in the settings menu as graphics and they indicate the resulting speed at different speed levels. This selection menu appears when you touch the arrow behind the symbol currently shown on the screen.

Note: A locomotive should not be changed whose decoder has been coordinated with it at the factory. This possibility for making settings is a very complex area in which individual parameters depend on each other in many ways. As a rule a layperson will make the running characteristics for a locomotive worse by attempting to reprogram these characteristics.

4 = Function Assignment / Mapping

This control area can be used to determine on certain decoders which functions are active and which function buttons will be used to control them.

5 = Sound Settings

On certain decoders with built-in sound modules different parameters can be set here. The most interesting thing is setting the volume. On certain decoders you can adjust the operating sounds to the running characteristics of the locomotive.

6 = Special Options

Additional characteristics can be set in this menu for several types of decoders. These characteristics relate to the handling of data about the running of the locomotive. We recommend that you keep the factory settings for these decoders. On several decoders there is also a field with the designation "RESET". If this field is activated with your finger on the touch screen, then the decoder in the locomotive is returned to the factory default setting. This also contains the locomotive address for locomotives without the mfx technology! In unfavorable situations it may happen that the address in the locomotive list

no longer agrees with the address set in the locomotive decoder after a decoder reset has been carried out.

Important! Do not confuse the reset for a locomotive with the reset for the entire Central Station. In the one situation the locomotive decoder is returned to the factory default settings; in the other situation the Central Station is returned to a defined starting condition.

Operation Notes for the Settings Fields in the "Advanced" Submenu

As already indicated, the individual settings fields in the submenus depend on the different types of decoders (mfx decoders, digital decoders with coding switches, digital decoders with external programming, etc.). Which parameter is being set can be reconstructed easily as a rule from the text on the screen. The particular status in for a parameter can be changed by touching the corresponding field on the screen. Such a characteristic is either activated or deactivated by entering or deleting a check mark, or in the case of variable settings a cursor bar will appear, which can be changed with the arrow buttons located on the left and right.

Changes involving the programming of a locomotive without mfx technology are only registered by this locomotive when it is on a programming track. The Central Station does not check whether the locomotive has registered the change correctly. If there is no contact with an mfx locomotive, this will be indicated by an error message. No changes can then be made to the parameters.

3.3.3. Controlling a Locomotive

After a locomotive has been set up in the locomotive list, it is then called up actively in the locomotive controller part of the Central Station.

Changing Speed

Locomotives are controlled with the red control knobs in the upper left (left locomotive controller) and upper right (right locomotive controller) corners of the Central Station.

Turning the control knob to the right - The locomotive runs faster
Turning the control knob to the left - The locomotive runs slower

The current speed set for the locomotive is shown on the display screen. The number of speed levels depends on the type of decoder used in the locomotive.

Turning the control knob further to the right after you have reached the maximum speed will not change the speed any more. The same holds true when you turn the control knob to the left, and you have already reached speed level 0.

Changing the Direction of Travel

Pressing on the control knob will change the direction of travel for the locomotive. The direction indicator on the display screen will change its position. The speed previously set for the locomotive will be reduced to speed level 0. The direction of travel can also be changed by touching the direction indicator on the screen.

Direction Indicator:
The right arrow is black - The locomotive is running forwards
The left arrow is black - The locomotive is running in reverse

Note: Not all decoders can make use of the direction indicator data. With these decoders it is possible that the direction of travel indicated on the screen is not the same as that of the model.

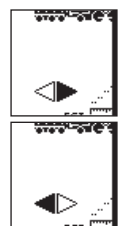
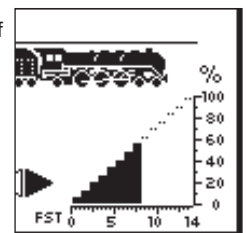
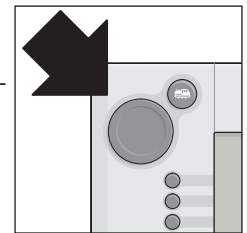

Tip: If you don't know whether a locomotive is evaluating direction data, a little test can help. Let the locomotive run a short distance. Note the direction of travel for the locomotive. Take the locomotive off of the layout. Change the direction of travel on the display. Set the locomotive back on the track and run the locomotive again with the locomotive controller part of the Central Station. Has the direction changed? Then, the decoder is evaluating the direction command.

Turning Auxiliary Functions On and Off

The controllable functions for a locomotive are represented with appropriate pictograms on the locomotive controller part of the Central Station. At the same time these pictograms also give information about whether the functions are on or off on the locomotive in question. See section 3.3.4. about setting up or changing particular pictograms.

The pictograms are divided up into two groups with 8 different positions per group.

The group on the outer edge of the screen can also be turned on and off with the function buttons located next to this group. Otherwise, all of the functions are turned on and off by touching the appropriate pictograms on the screen.

Note: Continuous functions (example: headlights / marker lights on a locomotive) are turned on by pressing the appropriate button or touching the appropriate pictogram once and are turned off by pressing or touching a second time. Momentary functions (example: locomotive whistle) are activated only as long your finger is pressed on the pictogram on the screen.

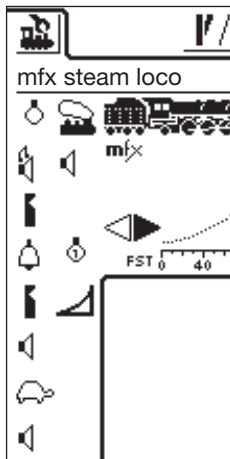

Calling up Another Locomotive in the Locomotive Controller

If you want to call up another locomotive or an item equipped with a locomotive or function decoder, you must select it from the locomotive list. To do this press the selector button in the upper left corner (for the left locomotive controller, in the upper right corner for the right locomotive controller) next to the control knob. A selection menu will appear on the display screen.

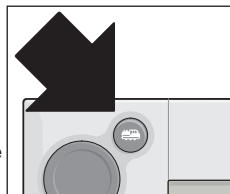

- 1 = Locomotive currently called up
- 2 = Sorting primarily by favorites
- 3 = Sorting primarily by locomotives currently in use
- 4 = Sorting primarily by the name of the locomotive
- 5 = Button: End without selecting a locomotive
- 6 = Button: Call up the locomotive selected
- 7 = One entry further down
- 8 = Cursor bar position in the list
- 9 = One entry further up
- 10 = Call up the locomotive on another controller.

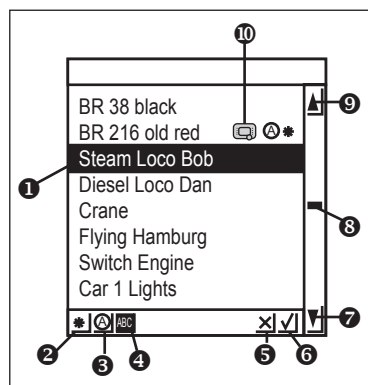

You can also search through this menu by turning the control knob. The locomotive currently being selected is called up into the locomotive controller part of the Central Station by pressing on the control knob for that locomotive controller.

The minute a command for running a locomotive (a speed level greater than 0) or for turning a function on is given, the locomotive or function model is designated as "active". You can sort in the locomotive list by this characteristic. Active locomotives cannot be deleted.

Multiple unit (M.U.) motive power (see following section) is also displayed in the locomotive list. Entries for these units have the additional designation of an "M".

Multiple Unit (M.U.) Motive Power

Two or more locomotive coupled together can also be controlled jointly with the Central Station. To do this, an entry is generated in the locomotive list, and this entry makes use of a new name to control the locomotives coupled together.

Tip: Press the "STOP" button before the following steps.

The procedure for generating multiple unit (M.U.) motive power: Press the button in the upper left or right corner of the display screen, which you use to access the submenu for the locomotive controller part of the Central Station. A selection menu will appear in which you select the line "New M.U. motive power". A submenu will open up for setting up a multiple unit (M.U.) motive power combination.

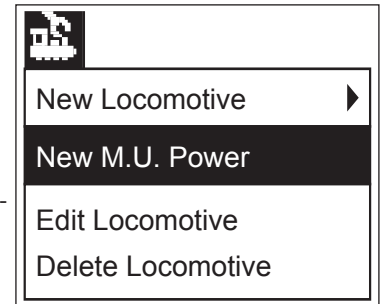

This consists of two overlaid entry levels with the designations "New Motive Power" and "Advanced". If this does not happen automatically, touch the "New Motive Power" part of the screen, so that this entry level is active. There you will find two selection lists. The left selection list contains all of the entries that have been put into the locomotive list.

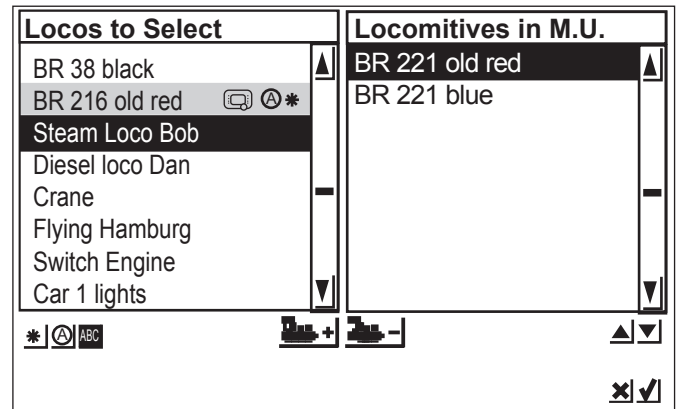

The first locomotive you want in a multiple unit motive power combination is selected by turning the left control knob. This locomotive is taken into the right list by pressing on the left control knob. Do the same process with the other locomotives, which you would like to put into a multiple unit motive power combination.

You can move the selection bar in the right "Locomotives in M.U." selection list with the control knob on the right side. The locomotive just marked in the list is deleted again by pressing on the control knob. The sequence of entries can be changed with the two arrows to the right under the right selection list. The particular entry that has just been marked is moved. Alternatively, locomotives in the selection list can also be accepted or removed with the two control fields in the center under the two lists.



You can select a symbol in the submenu "Advanced" to represent the multiple unit motive power combination in the locomotive controller. You can also give the multiple unit motive power combination a name, which you can use to select it from the locomotive list.

Leave the menu by touching the check mark in the lower right. The parameters you have just set are not stored in memory until now. If you touch the "x" in the lower right, then you leave the submenu without generating a new multiple unit motive power combination.

Note:

- Locomotives can only be put into one multiple unit motive power combination at a time.
- Multiple unit motive power combinations cannot be integrated into other multiple unit motive power combinations.
- Locomotives in multiple unit motive power combinations cannot be controlled separately, until the multiple unit motive power combination is deleted.

Tips for multiple unit motive power combinations:

- We recommend using only locomotives in a multiple unit motive power combination, which can evaluate direction of travel data.
- The locomotives you put into a multiple unit motive power combination should be fairly similar in their running characteristics (maximum speed, acceleration rate, etc.).
- Do not put lightweight locomotives or cars between locomotives in a multiple unit motive power combination. The combination may cause derailments!
- Keep in mind the total power requirements for a multiple unit motive power combination!
- Entries in the locomotive list for multiple unit or "m.u." combinations or lashups of locomotives are identified with an "M". The locomotives in this m.u. lashup are designated with an equipment symbol.
- When you are using multiple unit lashup, make sure that the signal block is long enough (at least 36 cm to 54 cm / 14" to 21" longer than the length of the locomotives coupled together in an m.u. lashup).

Recommended combinations:

1. All locomotives are mfx locomotives. The first locomotive in the m.u. list takes on the auxiliary function assignments. The function assignments can be set on mfx locomotives. For that reason the locomotives can be tuned to one another in terms of their running characteristics and auxiliary function assignments.
2. All locomotives are digital locomotives. We recommend that you use only models with the controllable high-efficiency propulsion. The first locomotive in the m.u. list determines the controllable auxiliary functions shown on the screen. Other locomotives in the lashup will respond to the auxiliary function buttons for the first locomotive, regardless of what auxiliary functions these other units may have. For that reason, you must select the models so there are not any inadvertent problems in operation. (Example: Locomotive 1 controls the horn with Function f3. Locomotive 2 controls the Telex coupler with Function f3. If f3 is activated or turned on, when the two units are together in an m.u. lashup, Locomotive 2 will uncouple from the train).
3. Locomotive + sound effects car (Examples: 49962 or 49964). The sound effects car is set as the first unit in the m.u. lashup and thereby determines the auxiliary function assignments.

3.3.4 Changing Locomotive Data

The data for a locomotive can always be changed. These data are the parameters already presented in Section 3.3.2. These parameters can be also be changed on mfx locomotives except for the address. Mfx locomotives don't need an address entry for identification. This assignment procedure is done automatically between the Central Station and mfx locomotives, when the Central Station is first initialized. The other parameters can be changed on these locomotives too. These parameters are then also stored in the mfx locomotive and are therefore available even if you change the layout and have a different Central Station or Mobile Station. You still have the possibility of changing the symbols for the individual functions in a separate area. For example, if you want to assign other function symbols to a locomotive, this can be done simply and easily with the Central Station.

Editing Locomotive Data

To change different parameters for an entry in the locomotive list, first press the button in the upper left on the display screen. Select "Edit Locomotive" in the following selection menu.

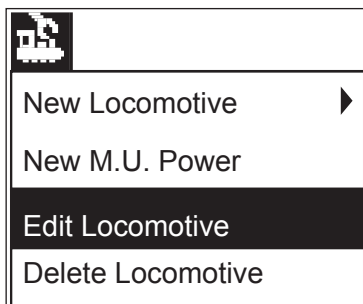

The settings menu (discussed in section 3.3.2.) for changing the name, address (on locomotives with Märklin Digital format decoders), the assignment to the favorites list, etc. will appear. Depending on the type of decoder, the analog behavior, maximum speed, braking delay, etc. can be changed in the "Advanced" submenu. Read the notes in section 3.3.2. for this.

Adapting Function Symbols

Press on the symbol for changing the control fields. A screen will appear on which the current control field for the solenoid accessories and the two bars for the function buttons are represented inverted.



The function buttons are organized into 2 columns with 8 entries per column. The outside column begins at the top with the headlight / marker light function. The functions f0 to f7 come under it. The inside column contains the functions from f8 to f15, sorted from top to bottom.

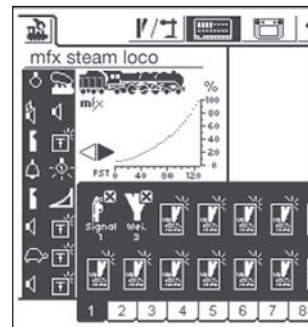

A search can be done from the selections for a symbol for each function. Simply press on the corresponding function to open the selections. A settings field will open up with different symbols. A function pictogram with a small "M" means that this function works as a momentary function. The function assigned to this button is on only as long as the control field is being touched during operation of the locomotive. A small "D" by a function means that the function assigned to the button in question is turned on by touching the control field on the screen and is turned off by touching this control area again. No confirmation is required for changes to the function pictograms.

Please note:

- Mfx locomotives must be in contact with the Central Station when changing function buttons.
- The Central Station does not check whether the pictogram makes sense or if it is even present. With different versions of decoders only those functions are shown on the display screen, which are theoretically the maximum that can be present.
- Please also note the references in Section 5 about the settings for the function display on the Central Station.

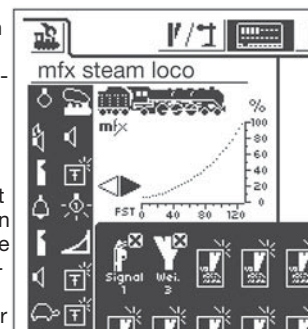

3.3.5 Deleting a Locomotive from the Locomotive List

Press the button in the upper left on the display screen to remove an entry in the locomotive list. Select "Delete Locomotive" in the following selection menu.

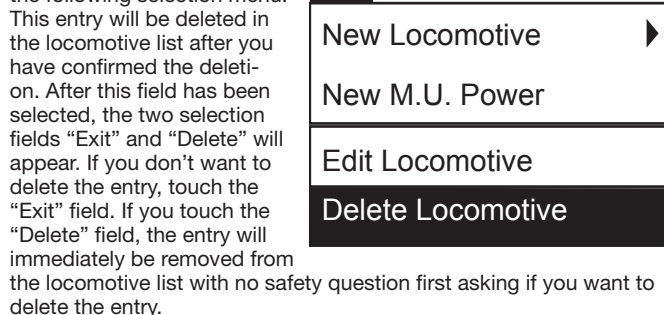

Important! Active locomotives (locomotives in operation) cannot be deleted!

4. Controlling Solenoid Accessories

Under the heading solenoid accessories are all of those accessories on a model railroad layout that are activated with one or more electromagnetic solenoid mechanisms. Among these types of accessories are turnouts, signals, uncoupler tracks, etc. Lights or motors activated by a relay also belong to this group. Since the k 84 decoder has four permanently installed relays, all products connected to this decoder also belong to this group.

Important! The Central Station can only activate solenoid accessories, when they are controlled according to the Märklin Digital format by means of a Märklin k 83 or k 84 decoder or some other Märklin solenoid accessory decoder (example: 74460 C Track decoder). Damages arising from the use of other makes of decoders are not covered by the Märklin factory warranty!

4.1. Connections for Decoders

The k 83 or k 84 decoders can be connected to the system in three different ways:

1. The decoder takes its data and power for the solenoid accessories connected to it from the track powered by the Central Station.
2. A ring circuit is set up from the Central Station for powering decoders. To do this, two 72090 distribution strips are inserted between the track layout and the Central Station, and additional wires are then connected from the distribution strips to the decoders.
3. The decoders can also be connected to a Booster instead of directly to the Central Station. Here too, the power for the decoders can be taken either from the track receiving its power from the Booster from a separate set of wires connected directly to the output terminals on the Booster.

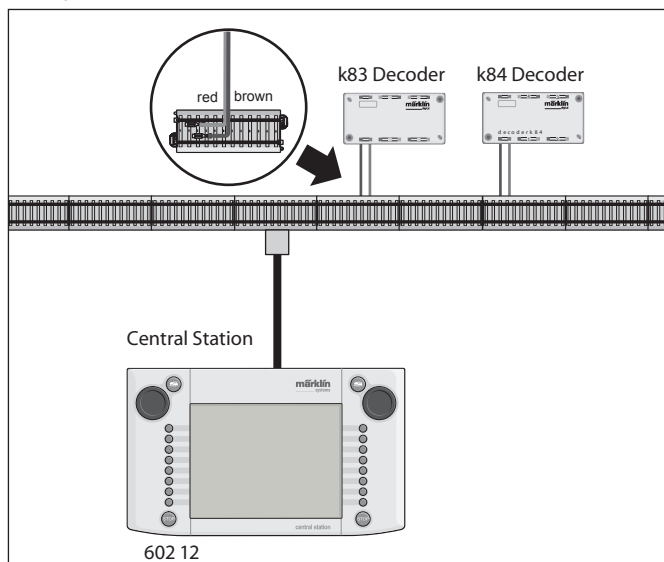

Tip: On large layouts it is best to separate the power supply for the operation of the trains from that for the operation of the accessories and power the two groups with their own power units (Central Station, Boosters).

4.2. Setting up / Processing Solenoid Accessories

A turnout or signal must first be taken into the internal solenoid accessory list, so that the accessory in question can be set up on the activation field on the Central Station. This can be done either separately in advance using the "Setting up / Editing Solenoid Accessories" submenu or when generating the activation fields.

Recommendation: Do not carry out the following steps, until you have pressed the "STOP" button (emergency stop).

Submenu "Setting Up / Editing Solenoid Accessories"

Press on the symbol "Setting Up Solenoid Accessories" in the upper menu list on the screen. A selection area will appear with three different selection fields:

1. Entering new solenoid accessories
2. Editing solenoid accessories
3. Deleting solenoid accessories



Select the control area "Enter New Solenoid Accessory". A settings area for entering different solenoid accessory parameters will appear on the screen.

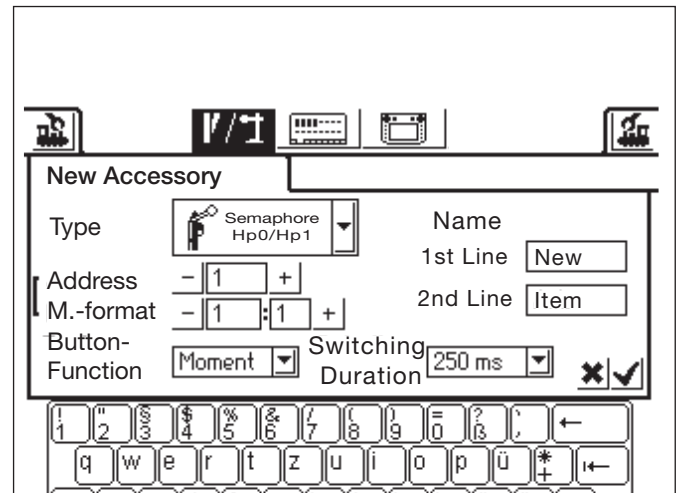

Type - The symbol for the solenoid accessory on the screen is generated with a selection menu. Simply touch the arrow in the selection field under the designation "Type". A new selection window will open in which you search for the appropriate screen symbol. This selection window can be navigated with the control knob or with the activation areas on the screen, as you have already seen with settings for locomotive.

Address - Enter here the digital address for the solenoid accessory in question. You can enter a value either numerically from 1 to 256 or in the form of a k 83 decoder number (1 to 64) followed by the exact position on the decoder (1 to 4). Make sure that you have the correct numbers from the coding list for the decoder. The Central Station does not check whether the address you set is already being used by another solenoid accessory.

Name - You can give a solenoid accessory a name so that it is clearly represented on the screen. Up to 2 lines with up to 8 characters (The number of characters depends on the width of the characters! The limit is thus between 5 and 8 characters.) can be selected with the keyboard.

Button Function - Here you can select whether the solenoid accessory is activated for a set time period (= Momentary) or for as long as the control area on the screen is activated (= Continuous). The function "Continuous" can only be used for solenoid accessories connected to the green socket on their k83 or k84 decoders. A typical application for the function "Continuous" is an H0 uncoupler track. Turnouts or signals are activated by means of the function "Momentary".

Switching duration - In this situation the switching duration that puts a solenoid accessory in the "Momentary" mode can be selected in five levels between 250 and 2,500 milliseconds. In practice a typical value for this is: 500 milliseconds. This setting has no effect on the "Continuous" mode.

After you have set the parameters, don't forget to store the new entry in the solenoid accessory list by touching the control area with the check mark in the lower right corner of the settings field. Touching the control area with the "x" to the left of it will take you out of this settings field without storing the data.

Editing Solenoid Accessories

Press on the symbol "Setting up Solenoid Accessories" in the upper menu list on the screen. A selection area with the three selection fields will appear. Select the control area "Processing Solenoid Accessories". A selection menu will appear with all of the entries in the solenoid accessory list. Navigate through this selection menu as already described previously (either with the control knob or with the control areas on the screen) until the entry you want to process has been selected. After confirming the entry, the settings field already described in "Setting up Solenoid Accessories" will appear. In this field you can change the parameters already described above such as type, address, name, button function, or switching duration. When doing this, don't forget that these changes are not taken into the solenoid accessory list until you have confirmed them (touching the control area with the check mark).



Deleting Solenoid Accessories

Press on the symbol “Setting up Solenoid Accessories” in upper menu list on the screen. A selection area with the three different selection fields will appear. Select the control area “Delete Solenoid Accessory”. The selection menu with all of the entries for the solenoid accessory list will also appear here. Navigate through this selection menu in the manner already described previously (either with the control knob or with the control areas on the screen) until you have selected the entry, which you want to remove from the solenoid accessory list. After you have confirmed the entry, the Central Station will not ask again if you are sure you want to remove the solenoid accessory in question from the solenoid accessory list.



Note: When a solenoid accessory is deleted from the solenoid accessory list, it is automatically removed from all applications in the different control areas.

4.3. Setting up a Control Area

The Central Station can have up to 18 control areas, each of which can have up to 16 solenoid accessories placed on it. These solenoid accessories come from the solenoid accessory list that you have already defined beforehand. These solenoid accessories can also be placed in different control areas at the same time. A change in the control status for such accessories is then updated automatically for all of the entries.

Depending on the operations status, the upper or the lower half for all of the control areas can be selected directly with the menu bar below the active control area you are using.

Simply press on the number for that control area. Control Area 5 is active in the example shown nearby. Control Areas 1 to 4 and 6 to 9 can be activated by touching their individual numbers. Touching the arrow button in the lower right will switch the screen to Control Areas 10 to 18.

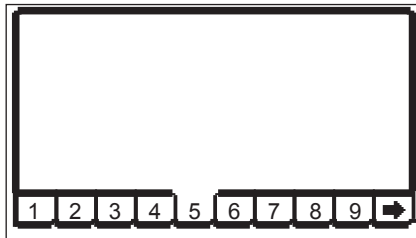

Recommendation: Do not carry out the following steps, until you have pressed the “STOP” button (emergency stop).

“Setting up Control Areas” Menu

Press on the symbol for changing the control areas. A window will appear showing the current control area for the solenoid accessories, and the two bars for the function buttons will be shown reversed. Only the control area is of interest for the following steps.



Note: The active control area can be changed at anytime during the following procedure by selecting another control area. No additional storage of the parameters is necessary for the following entries. Any changes you make will therefore take effect immediately.

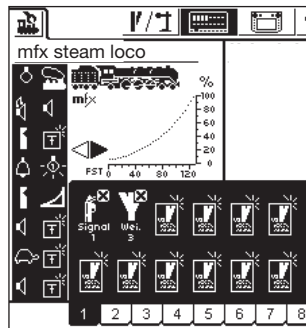

The control symbols are positioned in two rows in all of the control areas, with up to eight entries per row. Press on one of the symbols marking a free control area. Another selection menu will appear in which you now search for the line “Select from List”. This control area can either be activated by touching the screen or by turning and then pressing the control knob. A selection window will then appear with the entries in the solenoid accessory list.

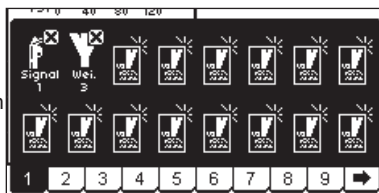

Pick out the desired solenoid accessory for the position on the control area currently selected. This too is done either with the control knob or with the indicated control areas.

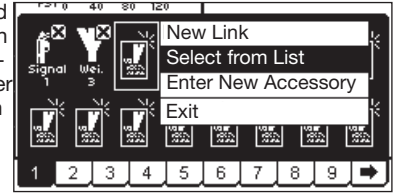

Notes about different types of solenoid accessories:

- A prerequisite for three-way turnouts and signals with several aspects is that the second solenoid must be connected to the address directly after the address for the first decoder connection. Example: three-way turnout – first address is 11 => The second address must be 12. 7241 signal with three aspects: Main solenoid is address 5 green and red => The address for the second solenoid must be 6 green! The red output for the second address cannot be used for other solenoid accessories!
- Always connect H0 uncoupler tracks to the green decoder output and set them up as a “Continuous” button function. 1 Gauge uncoupler tracks are set up as a “Momentary” function.
- Lights or other users connected to a k84 decoder are set up as a “Momentary” button function.

“Enter New Accessory” Submenu

As an alternative to the submenu “Select from List”, when you are setting up the control areas, you can also put turnouts or signals into the solenoid accessory list later by selecting the control area “Enter New Accessory”. These new accessories are placed at the selection position on the control area by using the procedure already described above for making new entries in the solenoid accessory list.

Note: If a solenoid accessory already in the solenoid accessory list is entered a second time, then both of these entries are treated as separate solenoid accessories despite the fact that they have the identical designation and/or address. When you activate the accessory in one entry, the display indicator for the other entry is not updated!

“Exit” Submenu

An activity you are doing with the accessories right now can be ended without changes to its status by selecting this control surface as an alternative to the submenus “Select from List” and “Enter New Accessory”.

Removing a Control Element

When you are setting up control elements on a control area, if you select a position already occupied by a control element rather than a free position, a submenu will appear for deleting the entry you are trying to make in the occupied position. There is also an alternative available for this procedure in the form of the control area “Exit”.

Note: An entry can not be replaced by another control element until the old entry is first deleted and then newly defined. If the parameters for an entry (example: the name) are changed in the solenoid accessory list, then these changes will be accepted.

4.4. Controlling Solenoid Accessories

1. Select the correct control area.
2. Touch the image for the solenoid accessory you want to control.
 - Solenoid accessory with two settings: The accessory will be switched from the current setting to the second setting.
 - Solenoid accessory with more than two settings: An additional control field will appear, from which you can select the desired setting. In the example to the right you can see the three possibilities for controlling a three-way turnout.

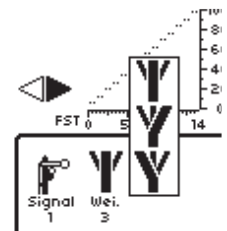

Note: When the Central Station is in the emergency stop state, solenoid accessories cannot be operated. Manual changes to the setting for the solenoid accessories are not recognized by the system.

4.5. Programming the 763xx Series Signals

The following steps must be carried out to program the 763xx series digital signals (Examples: 76391, 76393, etc.):

1. Leave the signal's electronic circuit in its packaging. The signal's electronic circuit must be clipped into the contact bracket in the packaging in order to be programmed.
2. Set up the appropriate controls for the signal in question in the solenoid accessory list on the Central Station. Make sure that you have the correct address set for the signal controls. Select the "Momentary" mode of operation for the button function. Important: Set the switching duration at 2,500 milliseconds for the programming procedure. On signals with a distant signal mounted on them, don't forget to set up the controls on the Central Station for the home signal part of these signals.
3. Place the new control element on one of the 18 operation levels so that you can control this solenoid accessory.
3. Turn the Central Station off.
4. Remove the connection for the Central Station to the layout. Only connect the new signal to be programmed to the layout output on the Central Station.
5. Turn the Central Station on. As soon as the Central Station is ready to be operated, press the STOP button (emergency stop).
6. Press the GO button on the Central Station. The signal aspect on the signal will begin to change back and forth between two states. The following procedure depends on the signal being programmed. 76391/76393/76371/76372: Activate the signal briefly on the screen. The signal will be programmed within the switching duration that has been set for its controls (2,500 milliseconds). 76392/76394: Switch the signal to aspect Hp1. Wait until the signal begins to show alternating different signal aspects. Now switch the signal to aspect Hp2. 76395/76397: The first step is the same as for the 76391 or 76393 signals. After that the distant signal will begin to change back and forth between two signal aspects. Now activate the signal aspect Hp1 or Hp0 for the home signal mounted on this signal. If the distant signal is assigned to a two-aspect home signal, then press the signal aspect function Hp1 or Hp0 a second time if the distant signal has started showing alternating different signal aspects again. In the other situation activate the signal aspect Hp2 on the home signal mounted on this signal.
7. The signal is now programmed. Turn the Central Station off. Remove the signal from its packaging and install it on the layout.

Important:

- Do not begin the other steps until the signal is first changing back and forth between the two signal aspects.
- It only takes a very short amount of time to activate the switching commands. The necessary switching duration is given with the entry of 2,500 milliseconds. When you are through with the programming procedure, you should change this switching duration to a value more commonly used for regular operation of the signals (Example: 500 milliseconds).
- If you pause too long between the individual steps, the signal will turn off the programming procedure on its own. In this situation, start the entire process again from the beginning by pressing the "STOP" button on the Central Station.

5. Other Settings

The Central Station also allows you to change several basic operations parameters. The submenu "Setup" is used to do this.

Recommendation: Do not carry out the following steps, until you have pressed the "STOP" button (emergency stop).

Press the setup symbol in the menu list on the upper edge of the screen. A selection field will appear, which will give you access to various selection fields.



General Settings

In this area you can set the language used on the Central Station, change the brightness of the background lighting, change the contrast for the screen, and carry out a "RESET" of the entire Central Station.

Important: When you do a reset of the entire Central Station, all of the data that has been entered is deleted! A reset of the entire Central Station is done without asking you a second time if you want to have the reset done.

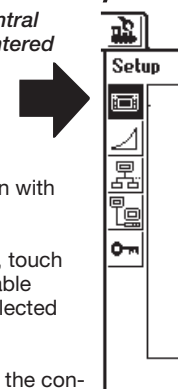

Do not confuse a reset of the entire Central Station with the reset of the data in a locomotive!

If you want to change the language on the screen, touch the arrow to call up the outer field. All of the available language versions will appear, and they can be selected by touching the word for the desired language.

The values set for the background lighting and for the contrast are represented by two horizontal bars. The values can be changed either with the control knob or with the control areas to the right and left of the bars. The bars must first be activated by touching them so that the control knob changes the values to the desired ones.

Note: Please have the hardware and software version numbers given in this settings field handy before you call the Märklin telephone service for help. This will result in a more efficient malfunction analysis.

Locomotive Operations Screen Settings

Possible Settings:

1. Assuming control of locomotives: Setting for whether a locomotive called up on one locomotive controller can be controlled at the same time on another controller. (parallel operation)
2. Numbering functions: On models with several functions it may happen that several auxiliary functions (example: sound effects functions) are displayed with the same symbol. Activating this function will result in consecutive numbering of these symbols.
3. Start Mode: Setting for whether the former operating data for locomotives (speed, direction of travel) is sent out to the models again after the Central Station is turned on.

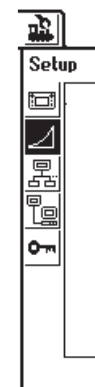

These functions are activated or deactivated by touching the square control area before the text for each function. Aktiviert bzw. deaktiviert werden diese Funktionen durch Berühren der quadratischen Schaltfläche vor dem jeweiligen Text.

Components in the System

With this submenu you can change various defaults for other components (Mobile Station) connected to the Central Station. All of the recognized components are first presented in a selection window. Using the methods already described before in this manual, select the desired component in this window. In our example in the upper right we are dealing with a Mobile Station connected to the Central Station. Using the following submenu, you can assign locomotives from the Central Station's locomotive list to this Mobile Station, locomotives which are to be controlled with the Mobile Station. You therefore have the possibility of allowing another operator to have access to a limited number of locomotives. The locomotive list in the Mobile Station has a capacity for up to 10 entries.

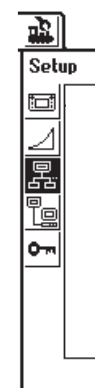

After you have selected the desired component, a settings field will appear in which locomotives for the Mobile Station's locomotive list are can be selected or removed from this list. This is done in the same manner as with the generation of a multiple unit motive power combination from the Central Station's locomotive list. The changes are not active until the

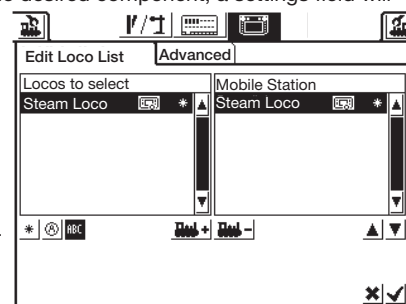

new settings have been confirmed (control area with the check mark in the lower right).

In the "Advanced" control area you have the possibility of changing or adding to the designation for the Mobile Station you have just selected. The keyboard blended into the screen will help you here. This function only makes sense, when more than one auxiliary Mobile Station is being used.

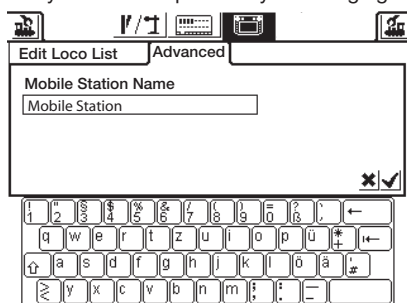

Important! When a Mobile Station with an older version of the internal database than the version present in the Central Station is connected to that Central Station, the database in the Mobile Station is automatically updated. This process can take as long as 2 minutes!

Network Settings

These settings are required for an update of the software in the Central Station. Please note the guidelines for the various update packets for these settings.

Access Settings

Certain functions can be blocked in this sub-menu. The individual functions are activated or deactivated by simply touching the square control area in front of each function.



6. Power Requirements

The power output for the layout can deliver a current with a maximum of 3 amps, when the 60052 / 60055 transformer is used. The maximum power is therefore about 45 to 48 VA. The programming track is supplied with a maximum of 1 amp. When this limit is reached, the Central Station will switch to emergency halt. This operating problem can be corrected by reducing the power requirements on the layout.

The following list of power requirements will help you compute your overall power requirements:

Single motor locomotive in operation	5 - 10 VA (1 Gauge up to 20 VA)
Sound effects circuit	5 - 10 VA
Smoke generator	2 - 5 VA
Light bulb	1 - 2 VA
Turnout mechanism	5 - 10 VA

If the power supplied from the Central Station is not enough over time, then the layout must be divided up into areas of equal size in terms of the power consumed. Each of these areas is then supplied with power from the Central Station or from a Boosters. The power supply to these layout areas must be electrically separated from each other (third rail insulation for H0, separation of the rail in 1 Gauge connected to the red wire from the Central Station and the Boosters). See the instructions for the 60129 Connect 6017 for examples of how to separate the power supplies.

7. Additional Notes:

Please note the following additional special features about this version of the Central Station:

1. You may have function problems with the first generation of 763xx series color light signals with their integrated decoders. Ask your authorized digital dealer about the procedure for updating the old signals for the new ones.
2. The 7686 digital turntable is (still) not supported with its own control area.
3. It is not possible to take a locomotive on a layout from Märklin Systems to another operating system. Catenary is not to be used with Märklin Systems to power locomotives and powered units. Caution! The Central Station will suffer damages if it is connected electrically to other operating systems!
4. Do you have ideas or wishes about future versions of the Central Station?
You can let us know about this easily at the Internet address "www.maerklin-systems.de". Please understand that this possibility for making entries is only for gathering customer reaction. You will therefore not receive a reply to your comments in this entry field. In future versions of the Central Station you may possibly see your information translated into new features. If you require technical help, please contact us at this e-mail address: "digitalfragen@maerklin.de"
5. Please make sure that you have made the connections in the right sequence! We are referring here to the sequence described in this instruction manual. Don't confuse the cable connection for the layout with the connection for the programming track.

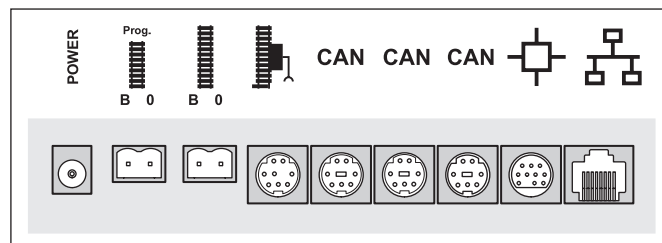

This device complies with Part 15 of the FCC Rules. Operation is subject to the following two conditions:
 (1) This device may not cause harmful interference, and
 (2) this device must accept any interference received, including interference that may cause undesired operation.

Gebr. Märklin & Cie. GmbH
 Postfach 8 60
 D-73008 Göppingen
www.maerklin.com

610 571 10 05 ma ef
 Änderungen vorbehalten
 © by Gebr. Märklin & Cie. GmbH